

Pressure Gauge w/ Low Pressure Switch

SG-FK5112 Fire Extinguishing System

Specification

General Description	Indicator for pressure of cylinder with alert for low pressure
4VcaZMReZ_?`Z	EX28621
> ReVGRJA	Stainless Steel/PolycarbonateA

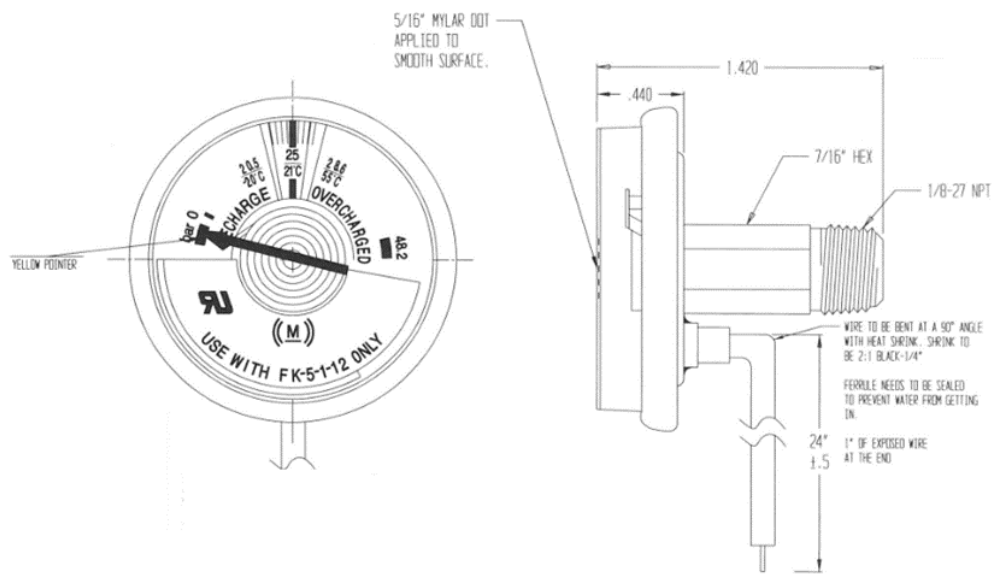

25 Bar Pressure Gauge with switch

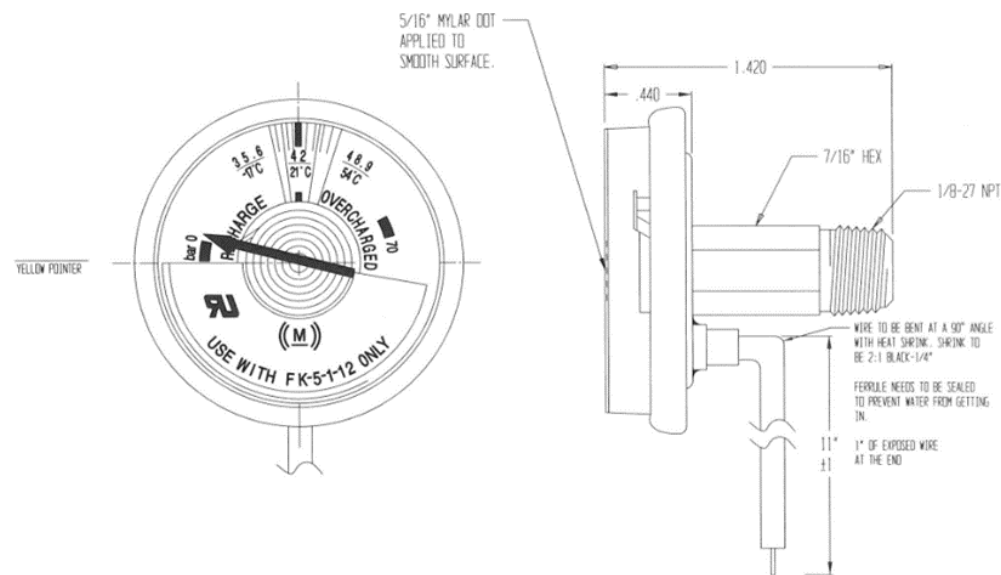

42 Bar Pressure Gauge with switch

HOCHIKI ASIA PACIFIC PTE. LTD.

82 UBI Ave 4 #06-02

Edward Boustead Centre, Singapore 408832 TEL: 65-6841-9728 |

FAX: 65-6841-9781 URL: www.hochikiasiapacific.com

02/2023



Approval / Compliance:

Component of FM & UL Listed SG Fire Systems

Pressure Gauge w/ Low Pressure Switch

SG-FK5112 Fire Extinguishing System

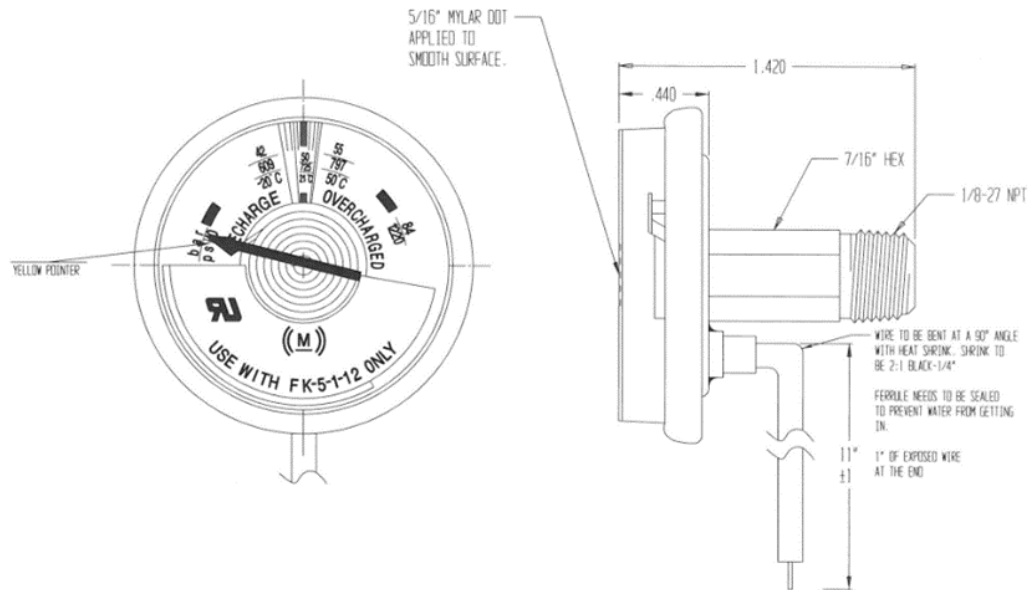

50 Bar Pressure Gauge with switch

Part Number	SG169-PS-25B-FK	SG169-PS-42B-FK	SG169-PS-50B-FK
Wire	18 Gage SXL, 24" in Length	18 Gage SXL, 12" in Length	18 Gage SXL, 12" in Length
Pressure	25 Bar	42 Bar	50 Bar
Crossover Signal	20.5 Bar	35 Bar	42 Bar
Temperature Range	-10°C to 60°C	-10°C to 60°C	-10°C to 60°C
Connection to Valve	1/8" NPT	1/8" NPT	1/8" NPT

Notes:

1. Normally open switch configuration
2. Wire Spec: 18 Gage SXL
Black Wire P/N: CST-SXL 18 0, SXL 18 Black – Cut/Strip/Tin
White Wire P/N: CST-SXL 18 9, SXL 18 White – Cut/Strip/Tin
3. Wires and pad print to be aligned and centred at the 6 o'clock position