

HOCHIKI

DFH-1A70

Fixed temperature type heat detector



Standard Features

- Non-waterproof type
- Low profile shape
- Utilizes a bi-metallic strip to sense temperature Change, therefore consuming no standby current and providing high reliability
- Base required (YBR-RL/1)

Application

The DFH-1A70 is 70°C fixed temperature heat detector are suited for installation where high heat output fires are expected or in areas where ambient conditions would not allow use of other detection methods.

The detector has a wide operation margin allowing it to response to both slow and fast increases in temperature, it can sense temperature reliably in a horizontal or vertical position.

Operation

The DFH-1A70 fixed temperature heat detector consists of a disk comprising of two metals, with considerably different coefficients of expansion, which are bonded together. When the ambient temperature exceeds the fixed temperature range of the detector, the disk bi-metal trips bringing the PGS (Platinum Gold Silver) contact points into contact, establishing a short circuit and triggering an alarm. When the temperature decreases the bi-metal disk returns to its initial shape and the contact open.

Dimension (mm)

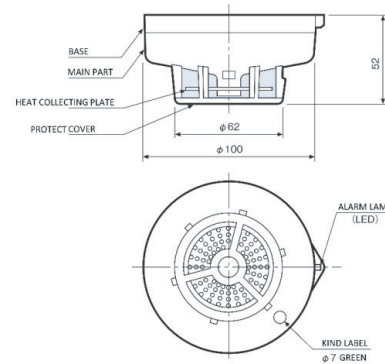

Specification

Type	Fixed Temperature Type
Model	DFH-1A70
Operating Temperature Range	-10 °C to 50 °C
Response	Temperature 70 °C
Operating Voltage	8.5Vdc – 30Vdc
Alarm Current	55mA @24Vdc
Material (Body) Heat Detection Element	Self-Extinguishing Resin Aluminum Plate & PGS Alloy
Color	White Ivory
Weight	Approx. 100g
Country of Origin	Japan
Approvals	JFEI

HOCHIKI ASIA PACIFIC PTE. LTD.

82 Ubi Ave 4 #06-02
Edward Boustead Centre, Singapore 408832
TEL: 65-6841-9728 | FAX: 65-6841-9781
URL : www.hochikiasiapacific.com

HEAD OFFICE

10-43 Kamiosaki 2-Chome.
Shinagawa-Ku, Tokyo 141-8660 Japan
TEL: 81-(3)-3444-4116 | FAX: 81-(3)-3444-4167
URL : www.hochiki.co.jp