

TTB3045.TM.NX - Telematics

Compact Scrubber Dryer

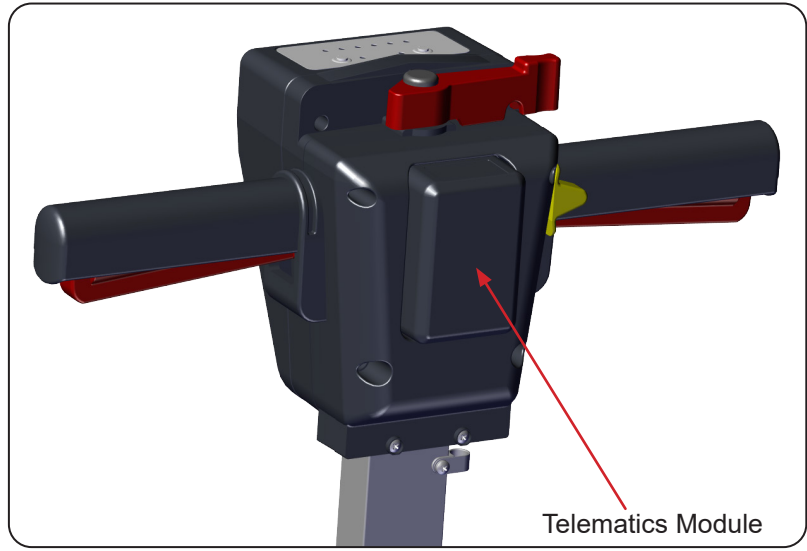

Supported bands of telematics module:

Type	Frequency / MHz	Max. RF Output Power / dBm)
LTE eFDD3	1710-1785	33
LTE eFDD 8	880-915	33
LTE eFDD 20	832-862	33
LTE eFDD 28	703-748	33
GMSK GSM 900	880-915	33
GMSK GSM 1800	1710-1785	33
8-PSK GSM 900	880-915	33
8-PSK GSM 1800	1710-1785	33
BLE	2402-2480	9.96
BR/EDR	2402-2480	13.41
WIFI	2412-2472	19.03

- **ToolSense Hardware Module:** An electronic device provided by ToolSense as part of the ToolSense IOT Kit that collects data and transmits it via wireless connection.
- The Telematics Module is constructed such that it may operate in all member states, No restrictions apply to the operation or use of this module.
- The telematics module contained within this product meets the European standards stated within the Declaration Document. It is the responsibility of the operator to ensure the environment in which the machine is used is Safe for the use of the signals within the range stated in this document.

SCHEMATIC

