

EN

Numatic



TBL8572/100T
TBL8572/150T

BATTERY
SCRUBBER
DRYER



Original Instructions

CAUTION, Read instructions before using the machine
Keep for future reference



Nu-Assist

Download on the
App Store

ANDROID APP ON
Google play



numatic.com

Index

Machine Overview	Pages 2-3
Control Panel Overview	Page 4
Machine Set up Guide	Page 5
Fitting the Brush / Pad	Page 6
Adjusting Deck Pitch	Page 6
Fitting the Floor Tool	Page 6
Fitting the Hose Guide	Page 7
Filling the Clean Water Tank	Page 7
Fill Level Indicator	Page 8
Lowering the Floor Tool	Page 9
Raise / Lower Brush Deck	Page 9
Setting the Cleaning Controls	Page 9
Brush Pressure	Page 10
Breakaway Floor Tool	Page 10
Machine in Use	Page 10
Machine Cleaning	Page 11
Waste Water Tank Full	Page 11
Changing Floor tool Blades	Page 12
Machine Charging	Page 13
Battery Care	Page 13
Charging Lights Sequence	Page 14
Free Wheel Function	Page 14
Specifications	Page 15
Trouble Shooting	Page 15-16
Rating Label / Personal Protective Equipment /Recycling	Page 17
Information for Scrubber Dryer	Page 18-19
Recommended Spare Parts	Page 20
Schematic Diagram	Page 20
Battery Information	Page 21-24
EU Declaration Document	Page 27
Warranty	Page 26
Company Address	Page 28

PLEASE READ BEFORE COMMENCING OPERATION

After the removal of all the packaging,
carefully open and check the contents

- Owner Manual
- 2 x Ignition Keys
- Battery Charging Lead
- 1 x 30 Amp Fuse (Brush)
- 1 x 20 Amp Fuse (Vac)
- 1 x 2.5 Amp Fuse
- Maxi Fuse-puller

1	Operator control panel
2	Charging Socket / Point
3	Clean Water Fill Point
4	Floor Tool Raise / Lower Lever
5	Clean Water Tank Emptying Hose & Fill Level
6	Vacuum Hose
7	Charging Lights
8	Brush Deck Lifting Pedal
9	Extra Brush Load Pedal
10	Semi Parabolic Floor Tool
11	Brush On/Off / Control Handle
12	Safety Fuse 2.5 Amp
13	Batteries
14	Brush Motor Fuse 30 Amp
15	Vac Motor Fuse 20 Amp
16	Brush Deck
17	Clean Water Filter
18	Water Pump
19	Waste Water Emptying Hose
20	Separator
21	Top Tank (Waste Water)
22	Bottom Tank (Clean Water)
23	Detent Pin
24	Key Ignition. On/Off
25	Battery Level Indicator

Machine Overview

TBL8572/100T = 2x batteries

TBL8572/150T = 3x batteries

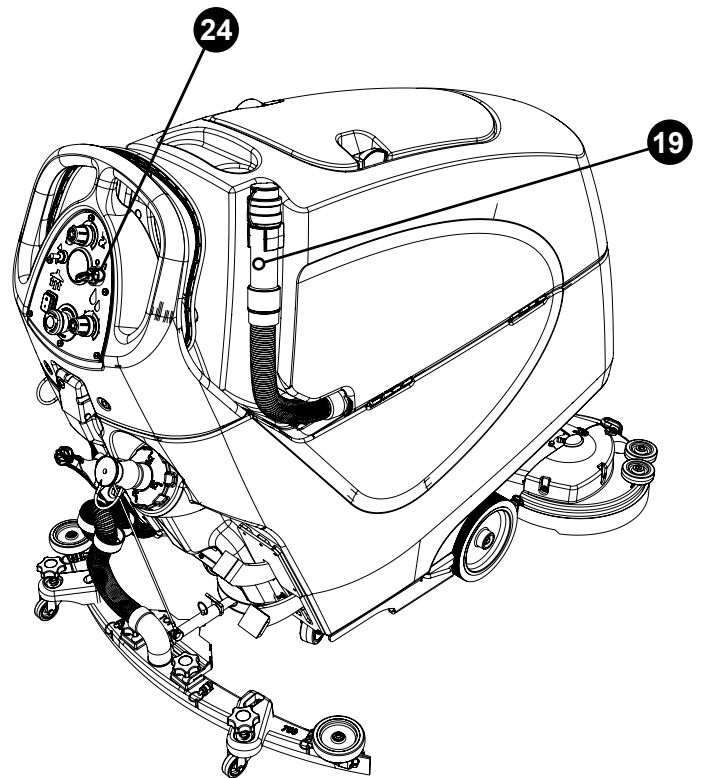
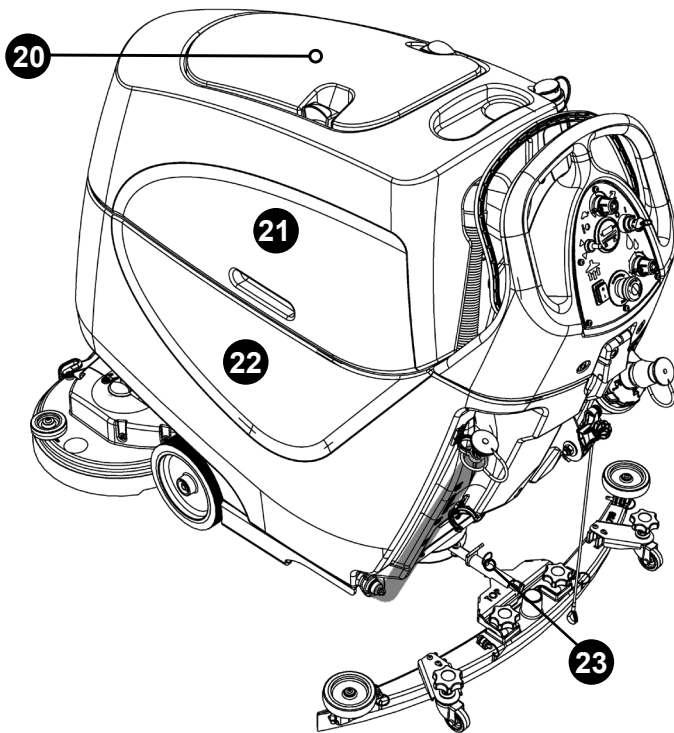
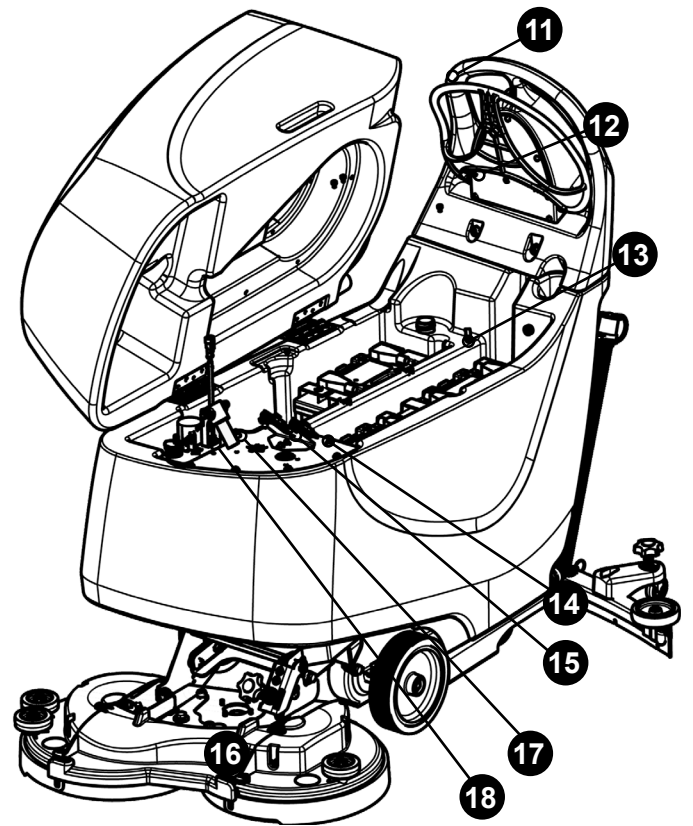
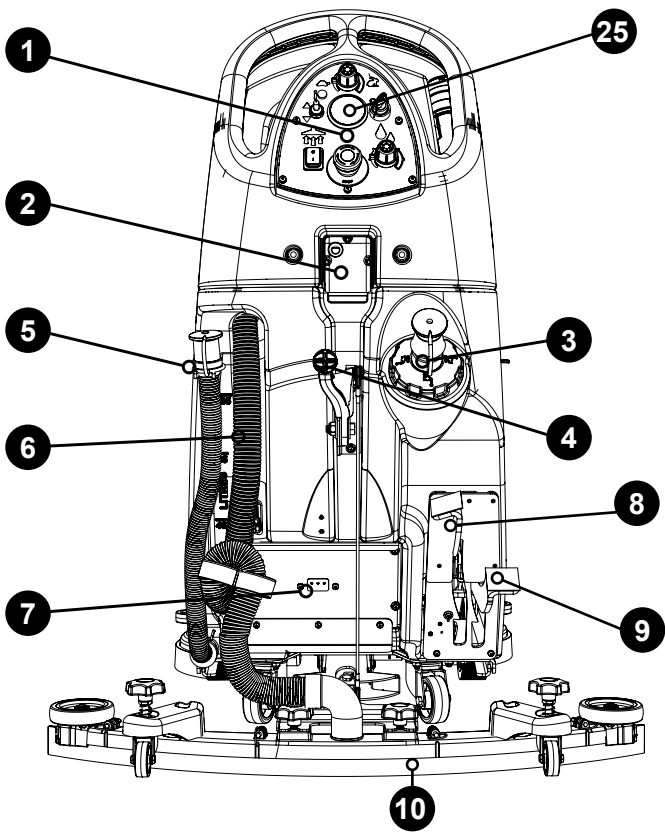

Control Panel Overview

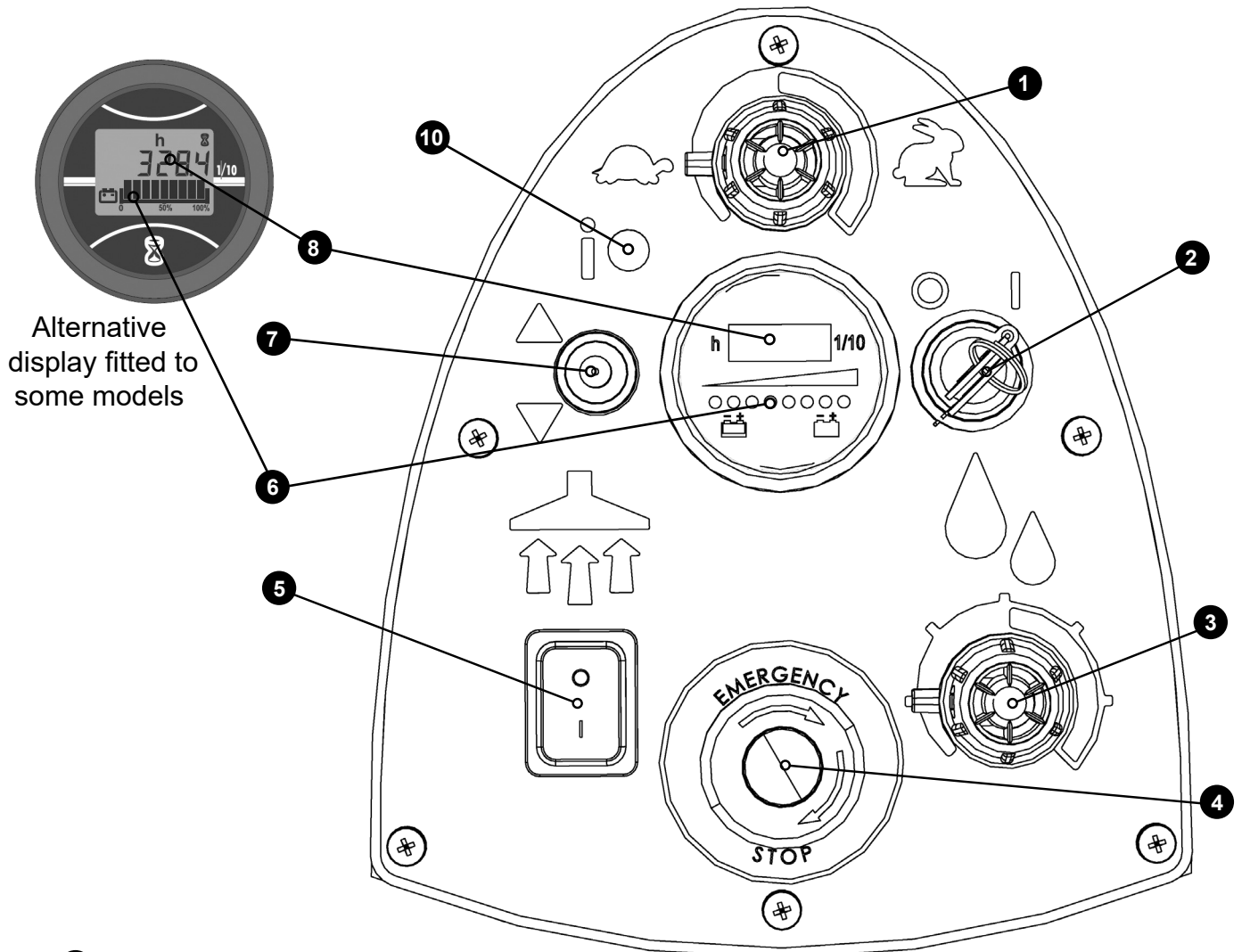

Alternative display fitted to some models

1	Traction Speed control
2	Key Ignition Switch
3	Water Flow Rate
4	Emergency Stop
5	Vacuum Pick Up On / Off
6	Battery Charge Level Indicator
7	Forward / Reverse
8	Hours Meter
9	Brush On / Off / Control Handle
10	Traction Status Light / Green Light Error Status (Page 16)

In the event of a breakdown contact your Numatic dealer or the Numatic Technical help line +44 (0)1460 269268

Machine Set-up Guide



PLEASE READ BEFORE COMMENCING ANY OPERATION AFTER THE REMOVAL OF ALL THE PACKAGING, CAREFULLY OPEN AND CHECK THE CONTENTS.



TBL8572 CONTENTS

- 2 x Ignition Keys
- 1 x 30 Amp Fuse (Brush)
- 1 x 20 Amp Fuse (Vac)
- 1 x 2.5 Amp Fuse
- Maxi Fuse-puller

Lift top tank assembly to reveal battery compartment, ensuring you use the handle grip provided.

Fit vacuum and brush fuses (contained in start-up pack) into the fuse holders as illustrated. (Fig. 1, 2, 3.)

Charge the machine to activate the batteries. After the batteries were activated, LEDs should illuminate on the top of all the batteries.

Insert Key into ignition located on the control panel (See below (Fig. A))

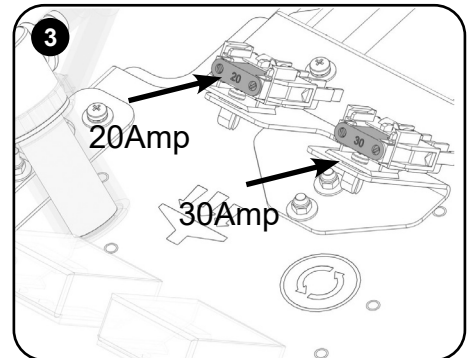
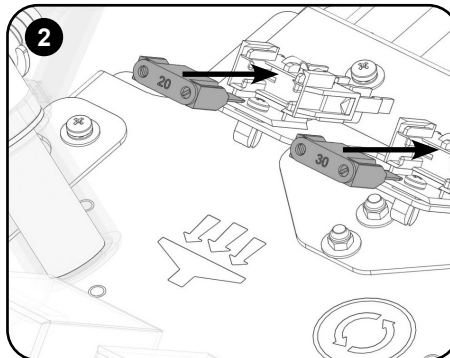
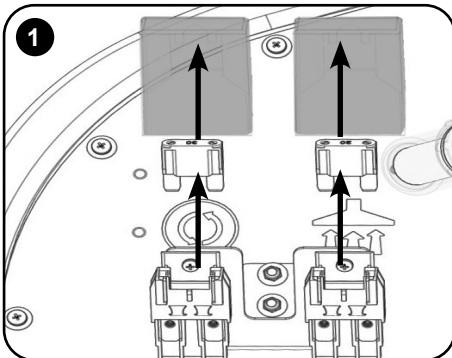
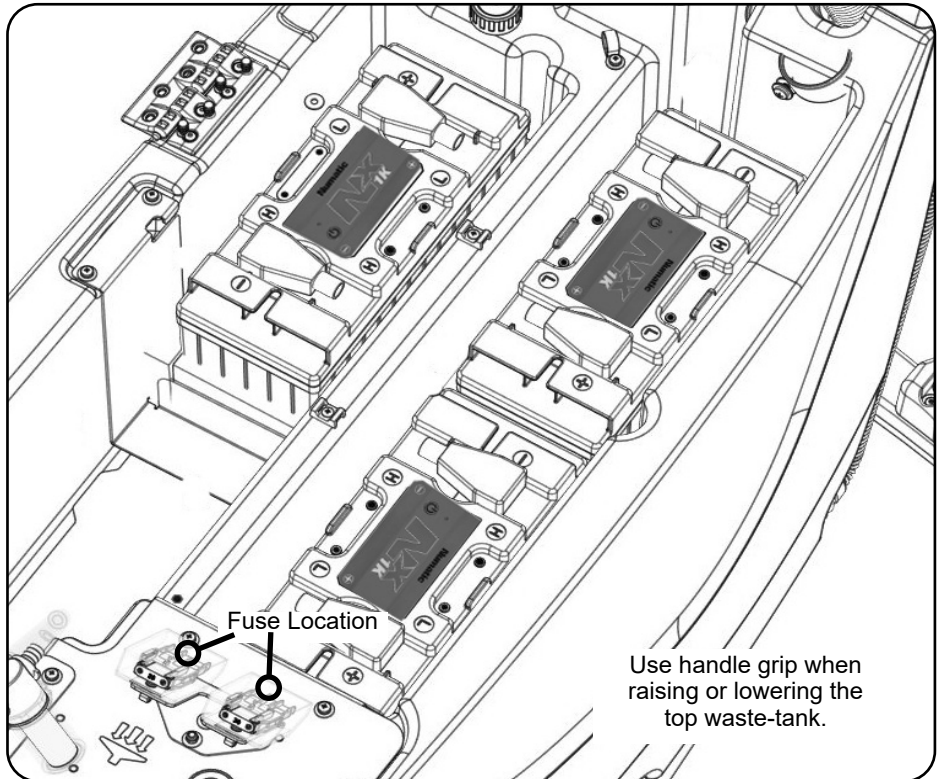

Numatic International Ltd recommends **ONLY** using 911948 NX1K LFP battery type Lithium Batteries provided with this machine.



ENSURE THAT NO METAL OBJECTS COME INTO CONTACT WITH BATTERY TERMINALS WHILE THE BATTERIES ARE EXPOSED.

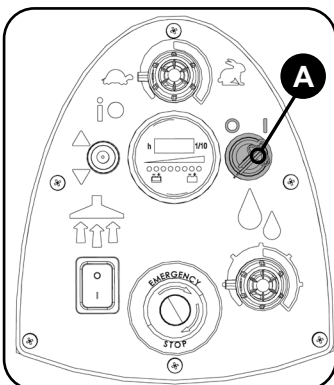

Insert the Ignition key and switch the machine on. (Fig. A)

Depress control handle with both hands (Fig.B) and slowly drive machine off of the pallet. When the machine is removed and in a safe position, turn key back to the position (0) 'OFF'
Note: During vehicular transportation ensure the product is secured to avoid unnecessary movement.

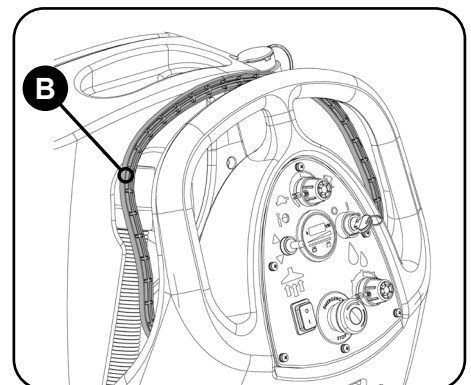

Machine Set-up Guide



ALWAYS ENSURE THAT THE MACHINE IS SWITCHED OFF BEFORE MAKING ANY ADJUSTMENTS



Fitting the Brush / Pad

Note: Safety gloves are recommended for the changing of used brushes.

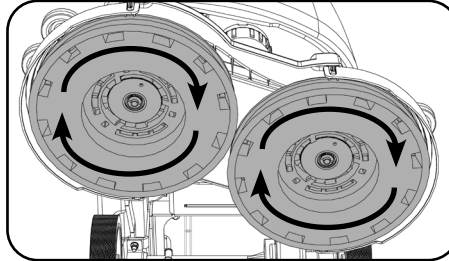
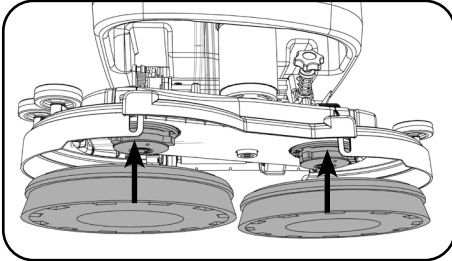

2 x 370mm Brush or a 2 x 360mm Pad on the TBL8572. Featuring the Nulock brush system. The brush is simply pushed and twisted to lock, making fitting and removal a simple process.

Slide the brush / pad under the brush deck.

Fit the brush / pad onto the Nulock drive chuck, twist to lock the brush / pad in place.

Brush Deck Pitch Adjustment

If the machine has a tendency to pull to either side while cleaning forwards, this can be compensated for by turning the brush deck pitch adjustment knob.

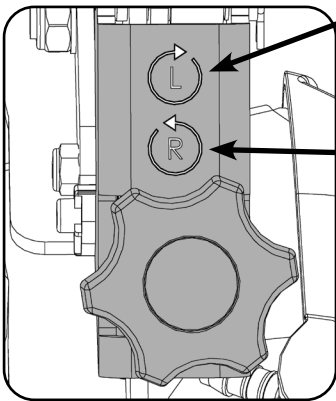

LH Bias: If the machine pulls to the right, turn the knob clockwise to apply left hand bias to the brush deck.

RH Bias: If the machine pulls to the left, turn the knob counter-clockwise to apply right hand bias to the brush deck.

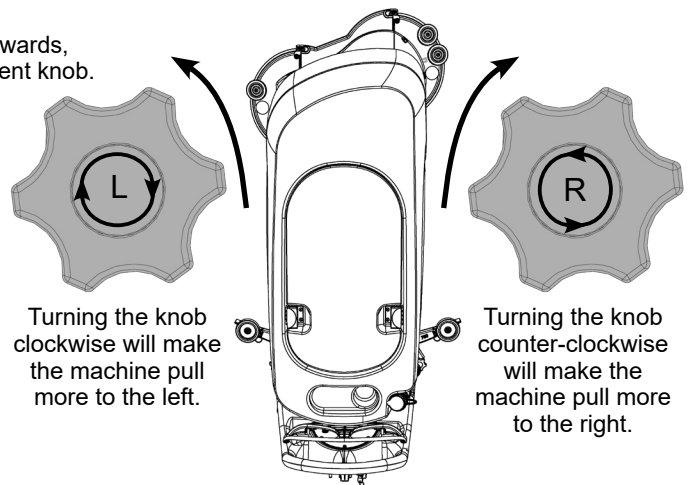
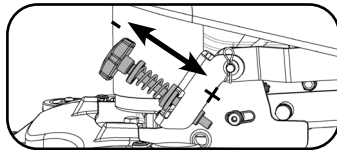

Turning the knob clockwise will make the machine pull more to the left.

Turning the knob counter-clockwise will make the machine pull more to the right.

Fitting the Floor Tool

The floor tool has been designed for quick fitting, allowing easy squeegee blade replacement and a safety knock-off feature if the floor tool gets snagged, whilst in transit.

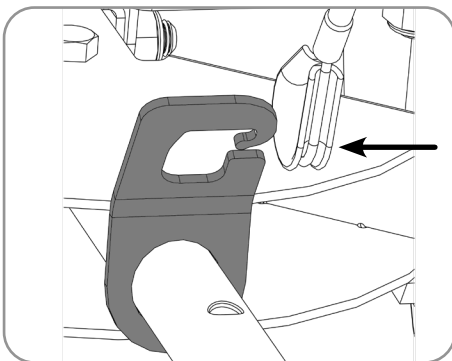

Fit the floor tool and retain using the detent pin.

Push vacuum hose onto the floor tool; ensure a tight fit.

Note: DO NOT push the vacuum hose onto the floor tool with the floor tool in the raised position.

Raise the floor tool for transit or lower for cleaning operation using the lifting handle fitted to the back of the machine.

For fitting the floor tool blades (See P12).

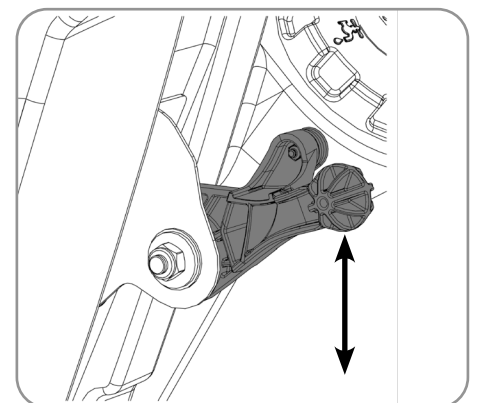
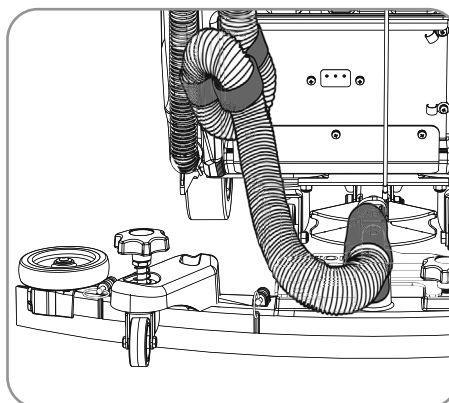
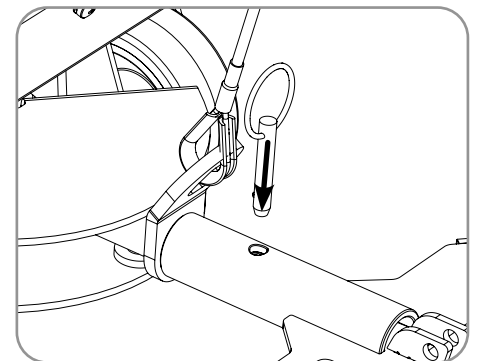
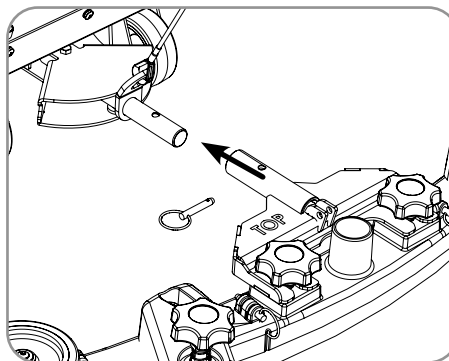

Machine Set-up Guide

Fitting the Hose Guide

The vacuum hose has a U-bend clip which creates a U-bend in the hose preventing water spillage when the vacuum is switched off. If you need to remove the U-bend clip for any reason always ensure it is refitted correctly before you resume operation.

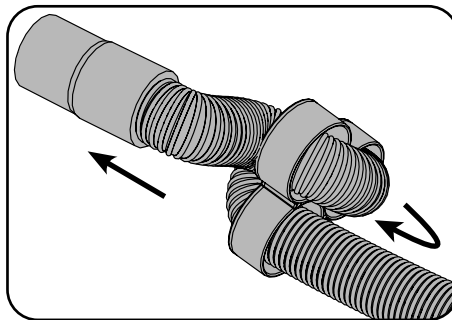
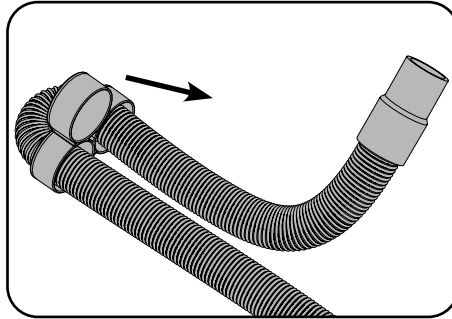
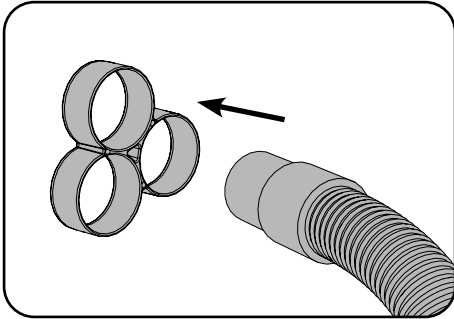

Note: DO NOT push the vacuum hose onto the floor tool with the floor tool in the raised position.

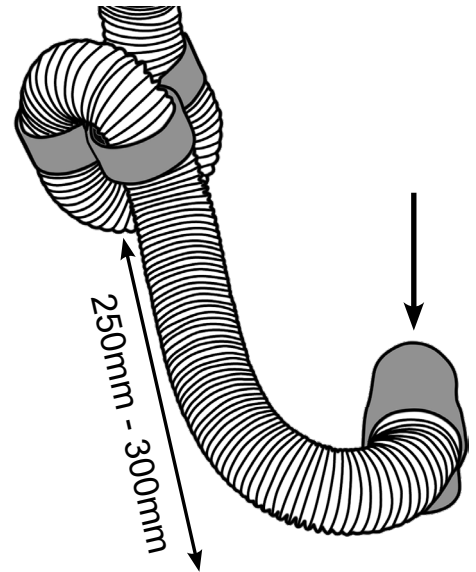

Refit vacuum hose to the Floor tool when finished.

Filling the Clean Water Tank

The TBL8572 is equipped with a large capacity clean water tank allowing for large areas to be covered in a single fill.

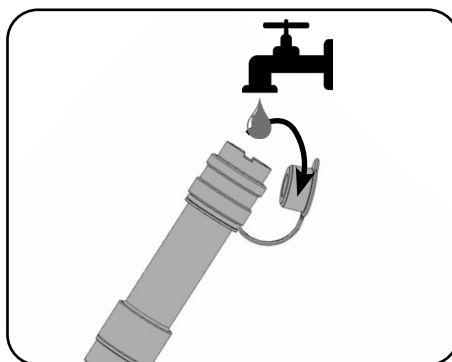
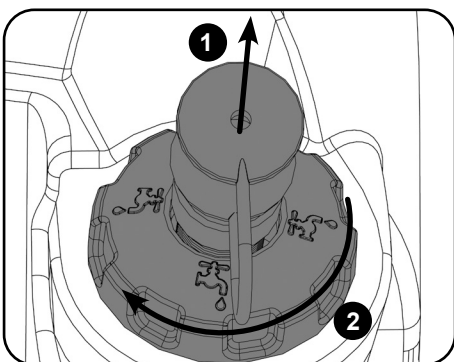

To fill the clean water tank, extend the hose located to the rear of the machine in the centre of the removable filler cap (1). Pull out hose. Open the stopper and place hose under water tap, or use a hose to commence filling. The tank can also be filled by unscrewing the filler cap and using a bucket or similar container (2).

Note: Great care must be taken to ensure that contaminants (leaves, hair, dirt, etc.) are not allowed to enter the clean water tank during the filling process. If using a bucket or similar, ensure it is always clean and free from debris.

Machine Set-up Guide

Fill Level Indicator

The water level in the clean-water tank can be measured using the scale on the rear of the machine. The clean water bottom tank holds 85 litres.

Note: always ensure that the waste water tank is empty before lifting.

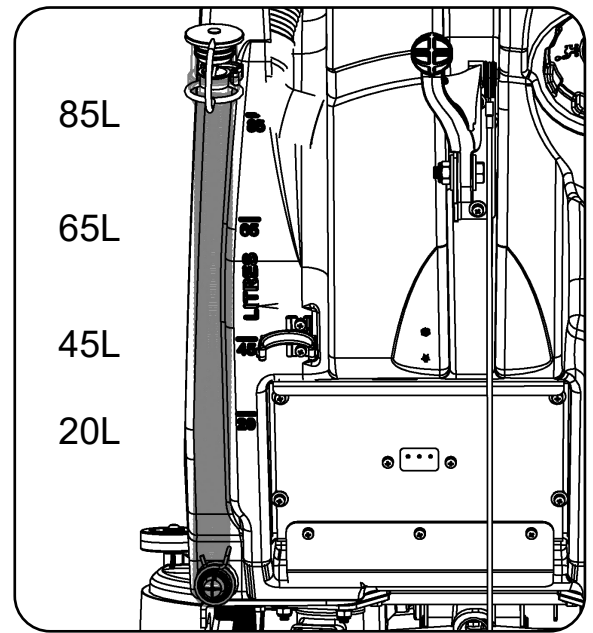

WHEN HANDLING AND MIXING CHEMICALS
Always ensure that chemical manufacturer's safety guidelines are followed.
Only use chemicals recommended for use in auto scrubber-dryers.



IMPORTANT
Do not operate machine unless the Operator Manual has been read and fully understood.



The machine is now ready to be moved to the cleaning site.

Before performing the cleaning operation, place out appropriate warning signs and sweep or dust-mop the floor.

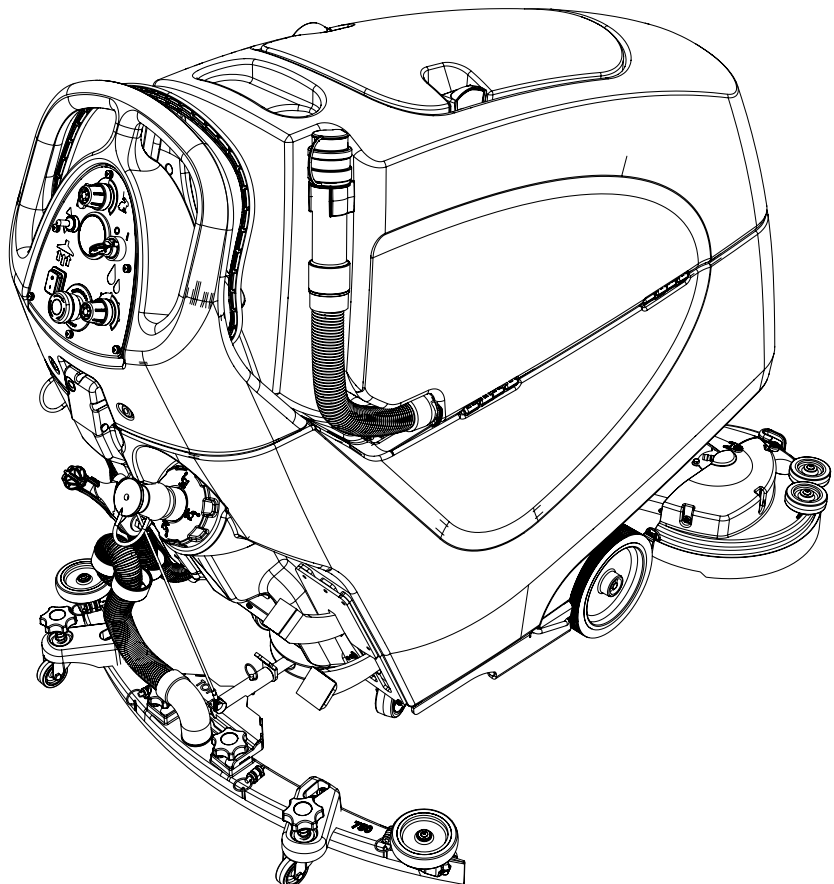
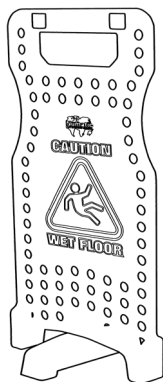

Machine Operation

Raising/Lowering the Floor Tool

After preparing the floor (see previous section), we are now ready to set the controls to suit the cleaning conditions. Before any settings can be applied, ensure the brush deck is lowered. Move the floor tool lever to its lower position.

Note: Do not drive the machine backwards with the floor tool in the lowered position, this could possibly damage the blades.

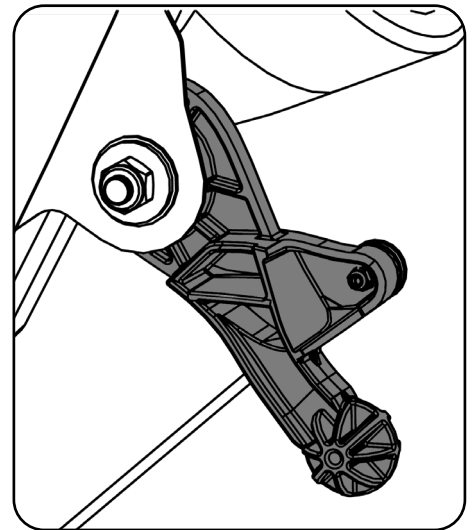
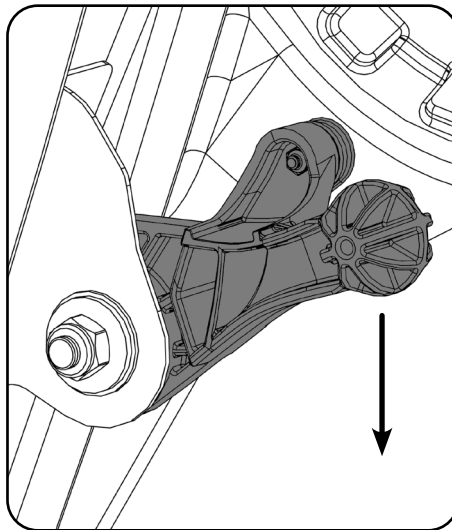
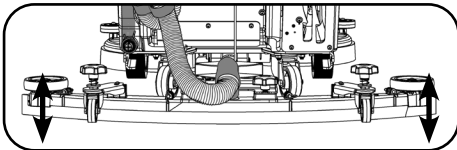

Raising/Lowering the Brush Deck

The control for lowering the brush deck can be found to the rear right of the machine. Lower the brush deck by moving the left hand release lever to the upper position.

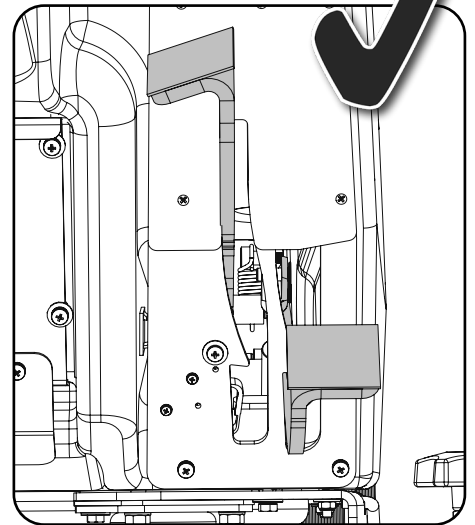
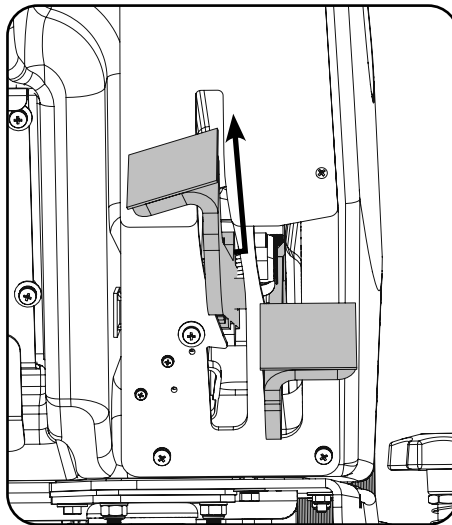
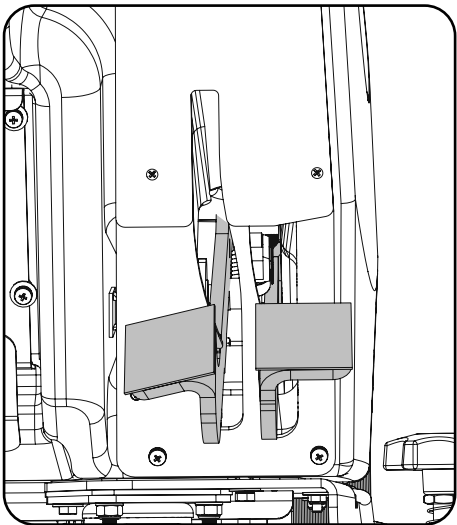
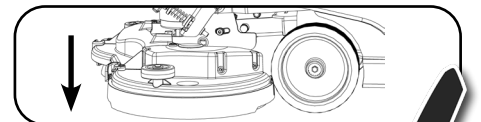

Setting the Cleaning Controls

Insert the key, turn the main control on / off key to position '1' (Fig.A). The traction status light will illuminate. Set desired traction speed as required, depending on floor type and level of soiling (Fig.B). Middle speed is the optimum cleaning speed. Set the flow rate (Fig.C).

The TBL8572 is equipped with an electronic braking system. Simply release the hand operated start / stop trigger and the machine will stop. In an emergency, strike the Emergency Stop button (Fig.D). The machine will be disabled. To reset, turn Emergency Stop button clockwise. After re-setting the Emergency Stop button, to restart the machine, turn the main control on / off key to '0' and then position '1'.

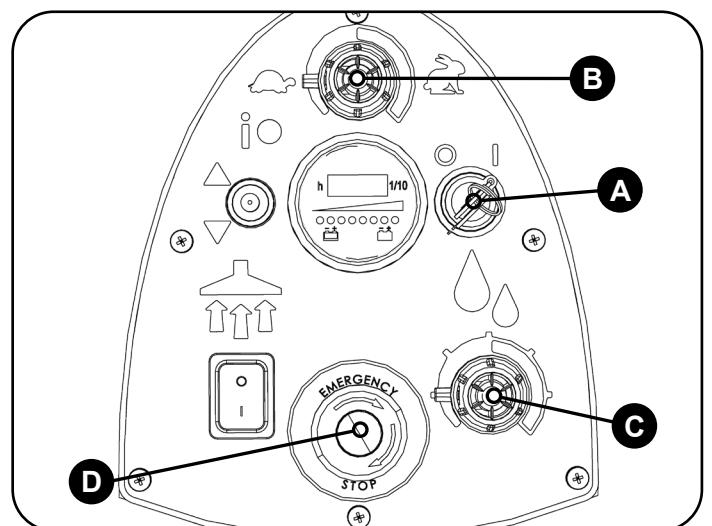

Machine Operation

Brush Pressure / Load Adjustment

The brush load lever is located to the right hand side of the machine.
This option is for hard to clean patches, adding extra pressure to the brushes.

**NOTE: It is recommended this option is NOT used all the time and is for spot cleaning only.
The run-time of the machine may decrease if the load on the brushes is increased.**

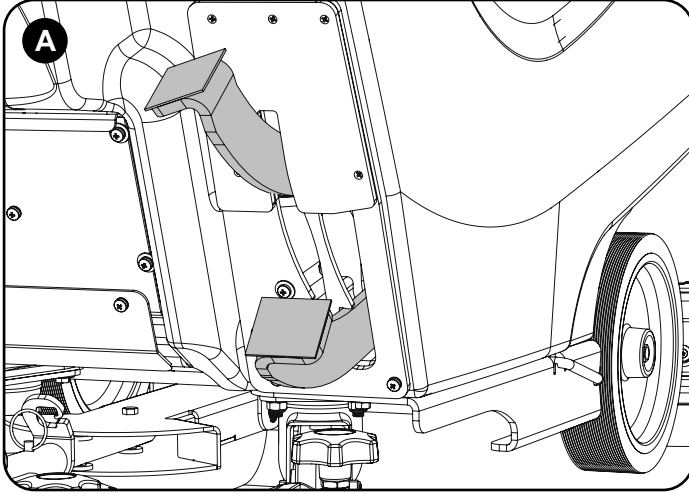

(A) Standard Duty
13 kg Pressure

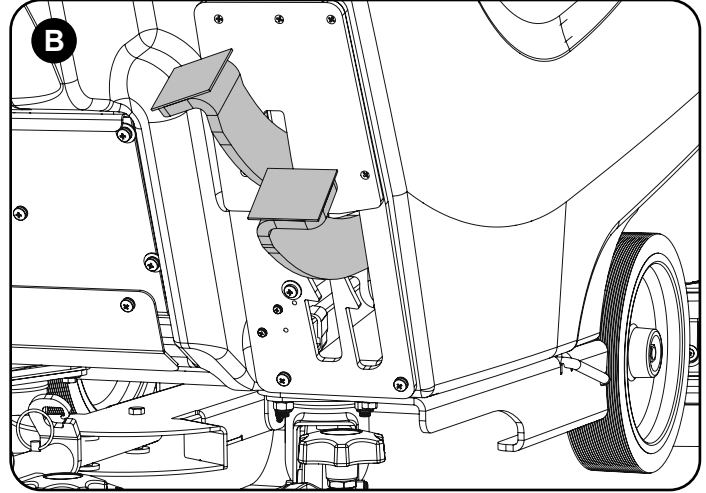

(B) Heavy Duty
28 kg Pressure

Break-away Floor Tool

The floor tool design incorporates a break-away feature.

Allowing it to safely disengage from its mounting should it become caught on an obstruction, during forward machine movement.

To re-attach the floor tool to its holder.
First loosen the retaining knobs on the floor tool body and slide onto the holding bracket.
Tighten retaining knobs to finger tight.

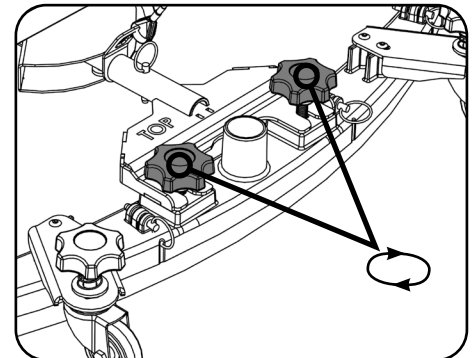
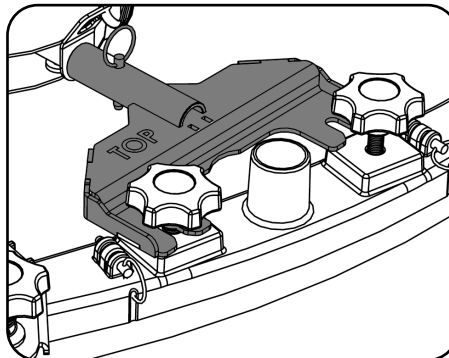

**ALWAYS ENSURE THAT THE FLOOR IS PRE-SWEPT
AND RELEVANT SAFETY SIGNS ARE DISPLAYED.**



Machine In Use

To operate, set water flow rate, lower brush deck, lower the floor tool, press the vacuum switch, pull brush On/Off trigger.
Adjust the speed to suit the conditions using the variable speed control, depending on floor type and level of soiling.
Middle speed is the optimum cleaning speed.

The waste water is then retrieved by the suction floor tool.
Overlap each scrubbing path by 10cm to ensure an even clean.
Do not operate the machine on inclines that exceed (6%) when full.

**Warning: While on ramps or inclines, avoid sudden stops. Avoid sharp turns. Use low speed down ramps.
Clean only while descending (driving down) the ramp.**

On heavily soiled floors use a 'double scrub' technique.

First pre-scrub the floor with the floor tool in the raised position, allow the chemical time to work then scrub the area a second time with the floor tool lowered.

If streaking occurs wipe floor tool blades clean.

Note: Care must be taken to reduce speed when cornering or when manoeuvring around obstacles

Regular Maintenance

ALWAYS ENSURE THAT THE MACHINE IS SWITCHED OFF PRIOR TO ANY MAINTENANCE USING THE MASTER CONTROL ON/OFF KEY. REMOVE THE KEY PRIOR TO ANY MAINTENANCE OPERATION.

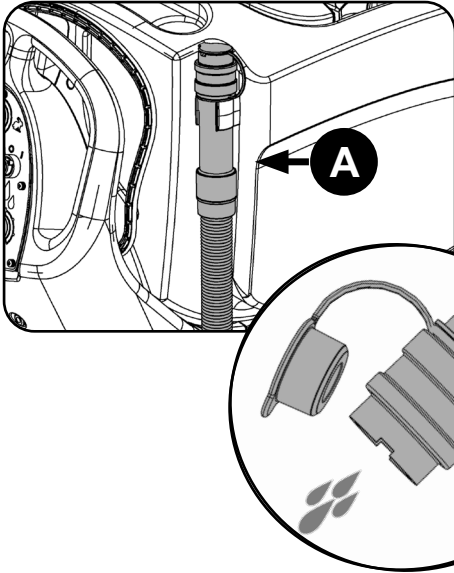

- A** After use, empty waste water tank using emptying hose and flush out with clean water.
- B** Next remove floor tool vacuum hose and flush out with clean water.
- C** Next empty clean water tank, using emptying hose and again flush out with clean water.

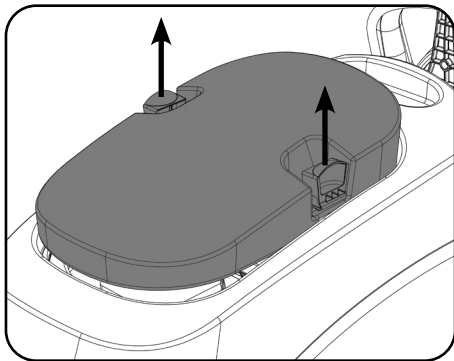
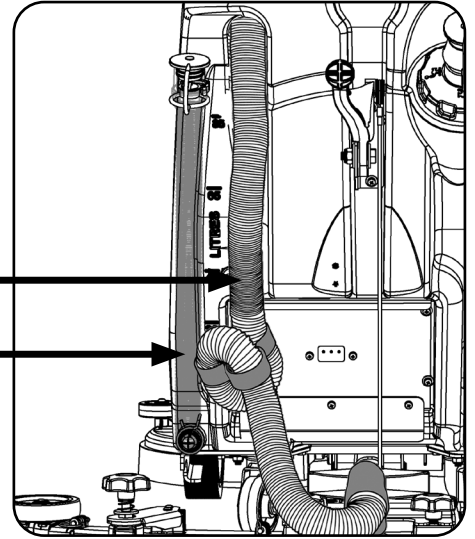

Whilst pressing in the top tank hood toggles, remove the hood. The hood also has a sealing-rubber which should be examined at every clean-down. Rinse using clean water, avoiding the vac filter.

Located in your waste water (top) tank is a full tank switch, this stops the vacuum from working once the waste water reaches its maximum limit. Sometimes the switch gets clogged and blocked, clean to ensure correct operation. Also please ensure float pad is clean and in correct position.

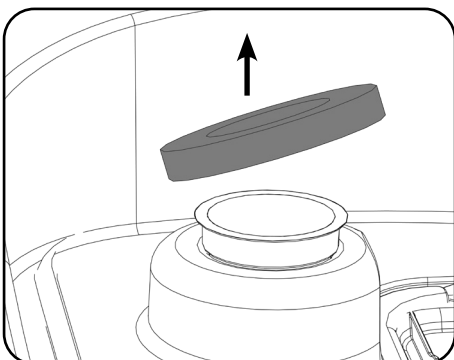
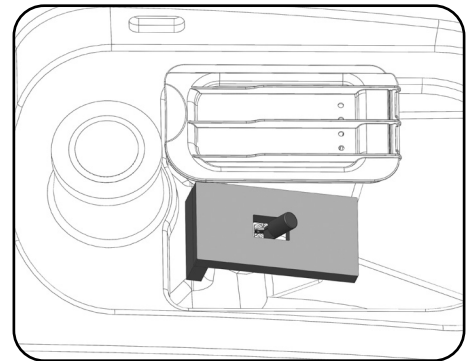

IMPORTANT
Remove vac filter and clean if required (keep dry). Never use the machine without the recommended filter as it may cause damage to the machine.

Remove debris basket filter and rinse using clean water, and refit. **IMPORTANT** If the debris basket is allowed to become clogged, vacuum performance can deteriorate.

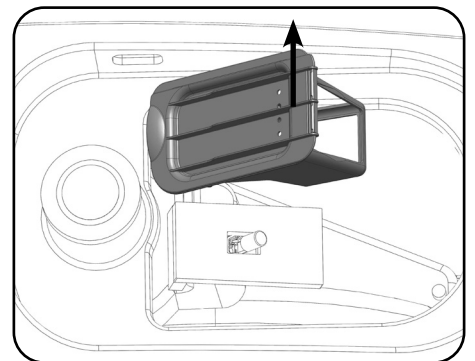

Located under the top tank at the front of the machine is a clean water filter.

Note: Make sure the top tank is empty before lifting.

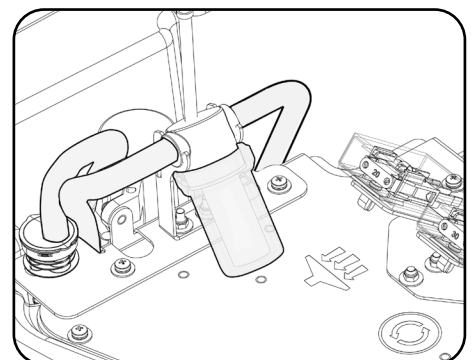

Changing the Floor Tool Blades



Always ensure that the machine is switched off prior to any maintenance.

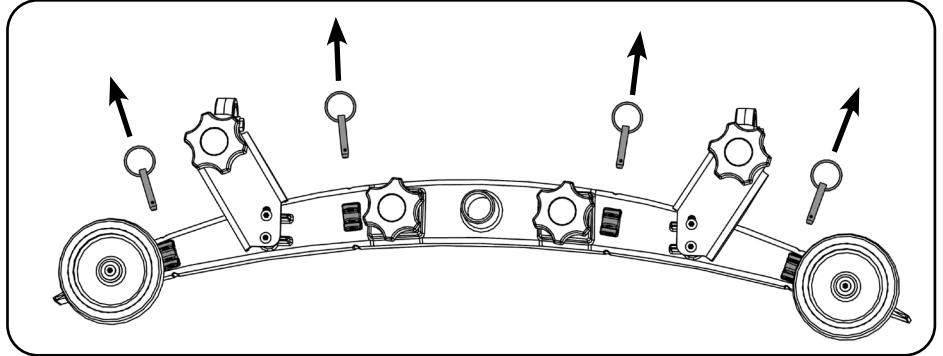
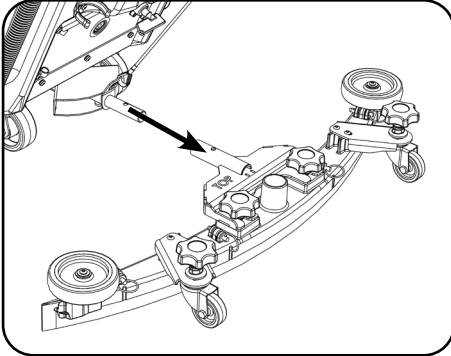

To clean the floor tool, remove securing-pin and pull-free from the holder. Rinse the floor tool assembly with clean water and refit.

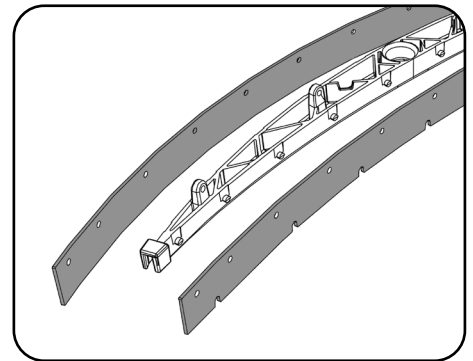
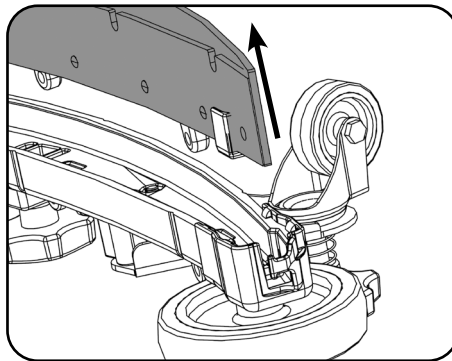
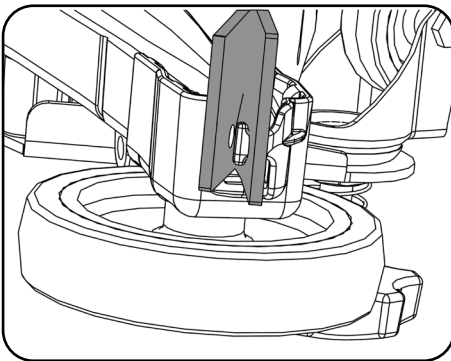

Periodically the floor tool blades should be examined and checked for wear and damage. The blade removal is easy. Simply start by removing the four retaining pins, turn the floor tool over and separate the blade carrier from the body. Peel away the blades from their locating lugs and examine or renew as required. Replacement is a reversal of the removal process.

Floor Tool Overview

1. Retaining pins x 4
2. Rear blade
3. Blade carrier
4. Front blade (slotted)
5. Floor tool main body

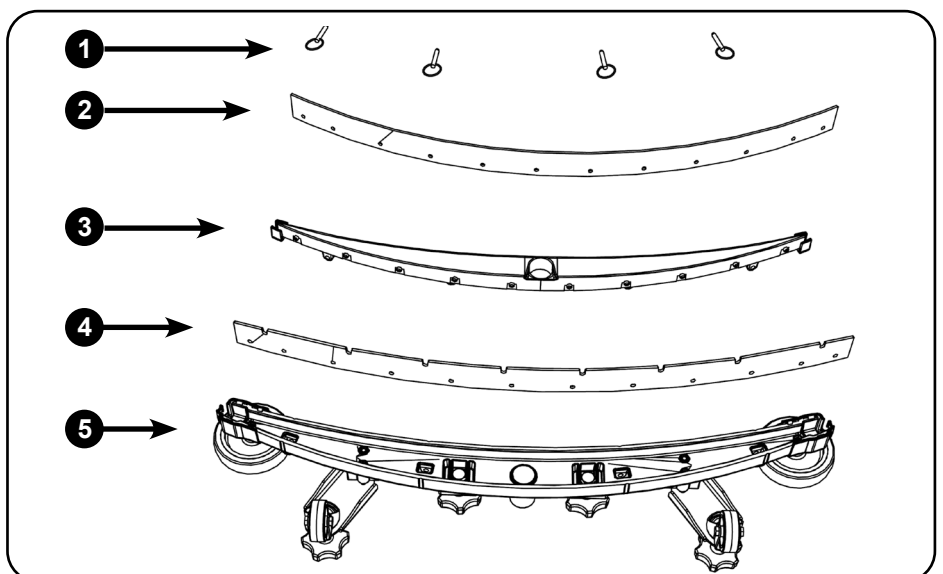

Note: The blades are designed to be reversible, thus extending their useful working life.

Machine Charging



Always ensure that the machine is switched off prior to charging.



The battery meter displays the charge level of the batteries; when fully charged, all meter lights are illuminated.

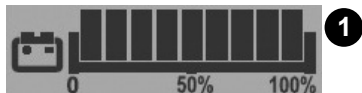

When the machine is getting close to empty the last light starts to flash, the operator should then take the machine to a suitable charging point.

When the battery icon starts flashing, the vacuum and brush motors will be disabled and the user should charge the machine.

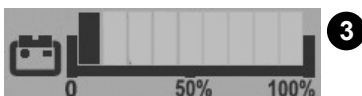

The LFP batteries are sealed for life and are totally maintenance free.

The on-board charger automatically monitors the charging process and will switch to float charge mode when the batteries are fully charged. Float charge mode allows to maintenance LFP batteries at the right level of health. The machine should be left on float charge overnight or over the weekend at least once per month or more frequently if needed.

Insert the charging lead required for your country into the charging point.

The machine charging point is located to the rear of the machine under the control panel.

Connect to a suitable power supply.

Once mains power is connected the red charging indicator will illuminate.

To ensure a full charge, from an empty state, the machine should be left for a period of 8 hrs.

Once fully charged, disconnect the charging lead from both the power supply and the machine.

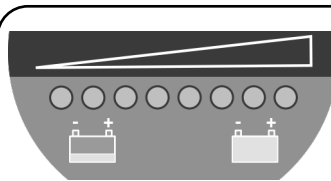

Alternative Display

When the last red light starts flashing, the vacuum and brush motors will be disabled and the user should charge the machine.

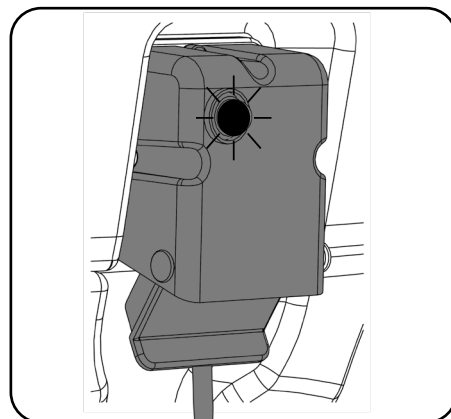
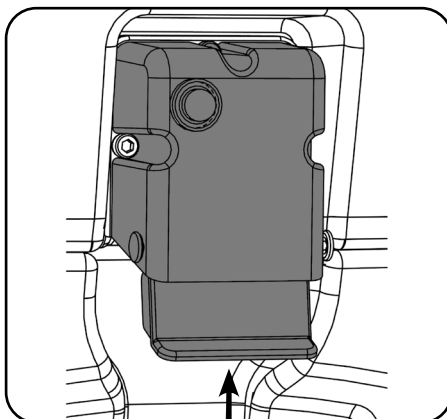
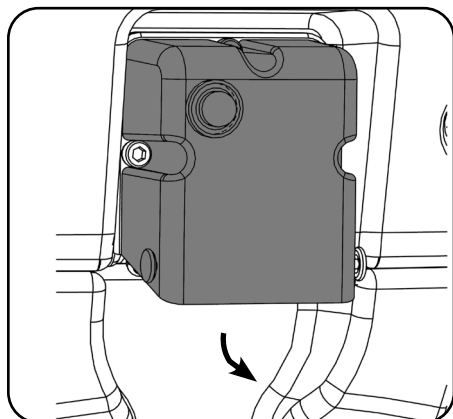

Battery Care



To ensure your machine remains at its maximum efficiency and prolong your battery life, please follow the simple steps below:



Under normal daily usage:

Re-charge the machine FULLY after each use regardless of machine operation time. It is recommended to leave the machine connected to power grid overnight, at least once a month. If the user does not disconnect the cable after full charge it is not an issue.

Do not leave the machine in a discharged state.



Periodically inspect the battery connections for tightness and corrosion.

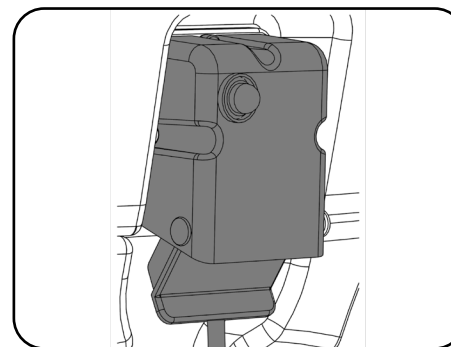

Charging Light Sequence

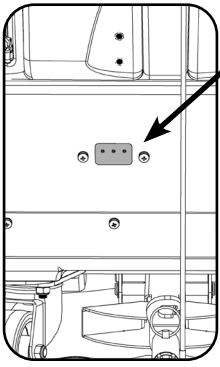

Signal (LED)	Meaning																
Red LED on	First Phase (Constant Current Mode).																
Orange LED on	Second Phase (Constant Voltage Mode).																
Green LED on	Third Phase (Constant Voltage Mode) Charge Complete. However, after full re-charge, leaving the charger connected moves to float-charge mode to help to maintain a healthy balance between batteries.																
Red LED flashing followed by Pause	Cooling Fan Locked > 1 flash between pause.																
	Over Voltage Protection / Output Short Circuit / Battery Reverse Polarity > 2 flashes between pause.																
	Over Temperature Protection > 3 flashes between pause.																
	Charge Time has exceeded 16 hrs during phase 1 or 2 > 4 flashes between pause.																
	<table border="1"> <thead> <tr> <th>Condition</th> <th>RED LED</th> <th>YELLOW LED</th> <th>GREEN LED</th> </tr> </thead> <tbody> <tr> <td>Pre-charge Timeout</td> <td rowspan="4">Flashing 4 Times</td> <td></td> <td>○</td> </tr> <tr> <td>CC Timeout</td> <td>○</td> <td></td> </tr> <tr> <td>CV Timeout</td> <td>○</td> <td>○</td> </tr> <tr> <td>Battery Disconnection</td> <td></td> <td></td> </tr> </tbody> </table>	Condition	RED LED	YELLOW LED	GREEN LED	Pre-charge Timeout	Flashing 4 Times		○	CC Timeout	○		CV Timeout	○	○	Battery Disconnection	
Condition	RED LED	YELLOW LED	GREEN LED														
Pre-charge Timeout	Flashing 4 Times		○														
CC Timeout		○															
CV Timeout		○	○														
Battery Disconnection																	
Note: ○ means illuminates continuously																	

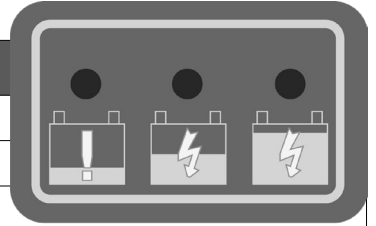

Note: Re-charge the machine fully after its last use. Do not leave the machine in a discharged state.

Under abnormal use; i.e. leaving the machine without charging for a period of time, we advise that you follow these steps:

Float charge mode allows to maintenance LFP batteries at the right level of health. The machine should be left on float charge overnight or over the weekend at least once per month.

Charge fully the day before you start using the machine again.



Free Wheel Function

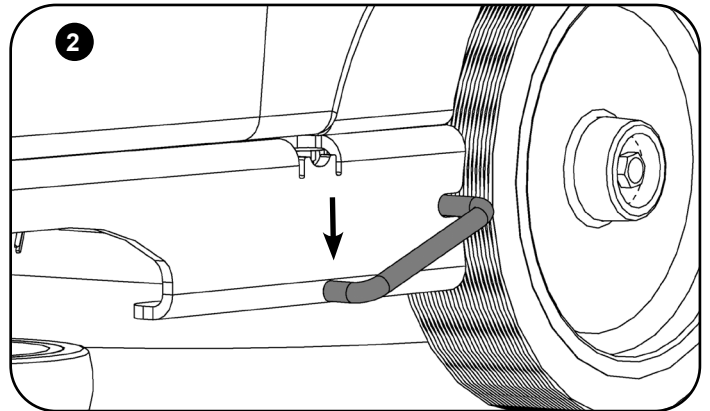
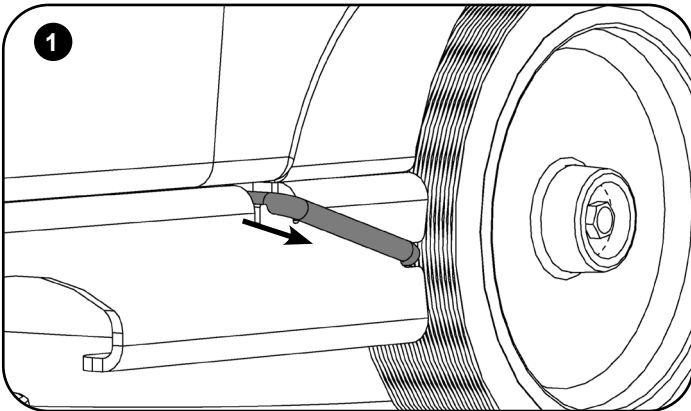

The machine is equipped with a free-wheel function that will enable the operator to move the machine manually if required. The motor brake is located on the right side of the machine near the rear wheel. Pull the arm out (Fig.1). Swing to the disengaged position (Fig.2). The motor brake will be fully disengaged. The machine will now be in full free wheel mode.

! ALWAYS ENSURE THAT THE MACHINE IS ON LEVEL GROUND BEFORE DISENGAGING BRAKE ARM. NEVER DISENGAGE THE BRAKE WHEN THE MACHINE IS ON A SLOPE / GRADIENT. !

Note: Drive functions on the machine will not work whilst in free-wheel mode. Remember to re-engage the drive when you reach your final destination / before using the machine.

Specifications

Model - TBL8572/100T & TBL8572/150T											
Brush Weight		Brush Sizes		Brush Pressure		Pad sizes		Pad Pressure		Cleaning Area	
13 / 28 kg		720mm (2 x 370mm)		8.2 / 17.5 g/cm ²		700mm (2 x 360mm)		6.9 / 14.8 g/cm ²		2592m ² /HOUR @ 3.6 kph	
Brush Motor		Brush Speed		Vac Motor		Vac Motor Suction @ Squeegee		Vac Motor Airflow @ Squeegee		Water Capacity	
600W		150rpm		400W		120 mbar		24 L/sec		85L	
Water Flow	Transaxle Power	Gradient	Drive Speed	Net Weight		Gross Weight		Power Source			
0 - 3 L/min	400W	Max 6%	0 - 4.2 km/h	100Ah : 204.11kg 150Ah : 214.91kg		100Ah : 289.11kg 150Ah : 299.91kg		2 Battery: LFP battery (Li-ion) 25.6 V (2x 50Ah) 2560Wh 3 Battery: LFP battery (Li-ion) 25.6 V (3x 50Ah) 3840Wh			
Run Time		Recharge Time		(Single Battery) Weight	Dimensions		Squeegee Width	Sound Pressure	Hand Arm Vibration	Water Ingress Protection	
100Ah : 3hr (MAX) 150Ah: 4hr 30 mins (MAX)		2 battery: 5 hrs 3 battery: 7 hrs 30 mins 20A Charger		25.6V 50Ah 10.7kg	Width = 762 mm Length = 1513 mm Height = 1144 mm		948mm	Lpa ≤ 70 dB(A)	≤0.54m/s ²	IPX4	

Trouble Shooting

PROBLEM	CAUSE	SOLUTION
Machine will not operate	Low battery charge Machine is connected and charging Waste tank full switch stuck or clogged Key is off or missing Handle safety fuse blown	Charge batteries (page 13 / 14) Take off charge (page 13) Inspect & clean switch inside tank (page 11) Insert key & turn to operating position Replace fuse (or contact service engineer)
Vacuum will not operate	Missing or blown fuse Waste tank full switch stuck or clogged Vacuum switch not engaged Waste water tank full	Fit or replace fuse (page 5) Inspect & clean switch inside tank (page 11) Press switch Empty waste water tank (page 11)
Poor water pick-up	Waste water tank full Clogged / blocked vacuum hose Loose hose connections Debris basket filter clogged / blocked Separator filter clogged / blocked Poor separator seal Damaged separator seal Damaged / split vacuum hose Damaged floor tool blades Low battery charge Floor tool incorrectly adjusted	Empty waste water tank (page 11) Remove and clean (page 11) Push tight connections (page 7) Remove and clean (page 11) Remove and clean (Page 11) Clean and refit (page 11) Renew (contact service dept) Renew (contact service dept) Renew (contact service dept) Re-charge batteries (page 13 / 14) Adjust floor tool
No brush / scrub function	No brushes fitted Brush deck raised Missing or blown fuses	Check and fit (page 6) Lower brush deck (page 9) Fit or replace fuse (page 5)
Little or no water flow	Clean water tank empty Clean water tank filter blocked / clogged Water flow not on Brush deck raised	Fill clean water tank (page 7) Remove and clean (11) Switch on water flow (Page 9) Lower brush deck (page 9)
Machine just 'stops' during operating	Too much load on the brush system Brush motor fuse blown due to high load Handle safety fuse blown	Decrease the brush load to best suit the floor type (page 10). Replace fuse & reduce load (page 5) Replace fuse (or contact service engineer)

Warning:- Do not fit a replacement fuse link having a higher rating than the value stated on the fuse label.

Failure to rectify the problem or in the event of a breakdown contact your Numatic dealer or Numatic Technical helpline +44 (0)1460 269268

Contact Service Agent

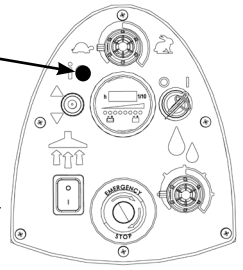

Green Status Indicator	Fault	Possible Cause	Effect on Product	Investigate the Following	Action Required	If Fault Persists
1 Flash with pause ●	Batteries voltage low	Batteries not been charged Possible bad connection between batteries, controller, charger or fuses caused by loose connections, damaged wiring, water ingress Not accepting charge due to faulty battery / cell Charger not functioning	Operating time severely reduced or machine will not operate	Check when machine last charged Switch OFF the machine : Remove Fuses Check connections to batteries, charger and fuses for loose wires or screws Check each battery Voltage individually to detect defect unit 10.5V min Check battery voltage and charge current ensuring charger red fault light is extinguished	Charge batteries immediately Tighten loose connections and replace damaged components Replace batteries as required Replace charger	
2 Flashes with pause ●●	Traction motor disconnected	The motor has a bad connection Motor disconnected TCO activated (Thermal Cut Out) Motor failed to open circuit	The motor will not operate	Check all connections and leads between motor and controller	Tighten loose connections and replace damaged components	
3 Flashes with pause ●●●	Traction motor wiring trip	The motor has a short circuit to a battery	Motor will not operate	Check all connections and leads between the motor and controller		
4 Flashes with pause ●●●●	Battery Lockout	The battery charge level has fallen below the battery lockout level and the controller is inhibiting machine functions	Machine functions not working	Check battery voltage and charge current ensuring charger red fault light is extinguished Check each battery voltage individually to detect defect unit 10.5V min	Charge batteries immediately	
6 Flashes with pause ●●●●●●	Charger connected	The controller is being inhibited from driving, this may be because the battery charger is connected	Machine functions not working	Remove charger to operate machine		
8 Flashes with pause ●●●●●●●●	Controller trip	A controller trip is indicated	Machine functions not working	Check all connections and leads	Tighten loose connections and replace damaged components	
9 Flashes with pause ●●●●●●●●●●	Brake deactivated or failed	Poor brake connections Brake failure or deactivation	Traction drive disabled	Check brake wiring and brake lever	Replace brake or wiring as necessary. Reactivate brake by engaging brake lever	
10 Flashes with pause ●●●●●●●●●●●●	High battery voltage	Poor connections between battery controller and traction motor	Machine functions not working	Check each battery Voltage individually to ensure voltage < 14 volts Check connections on controller batteries and traction motor Check combined battery pack voltage is < 28 volts		

About the Machine

Rating Label	
1	Company Name & Address
2	Machine Description
3	Supply Current / Voltage / Alternating Current / Frequency
4	Charger Output
5	Battery Voltage
6	Noise Rating
7	Hand Arm Vibration
8	Weight (ready to use)
9	Ingress Protection Rating
10	Max Gradient
11	QR Code
12	WEEE Logo / Approvals Mark
13	SKU / Part
14	Machine yr/wk Serial number

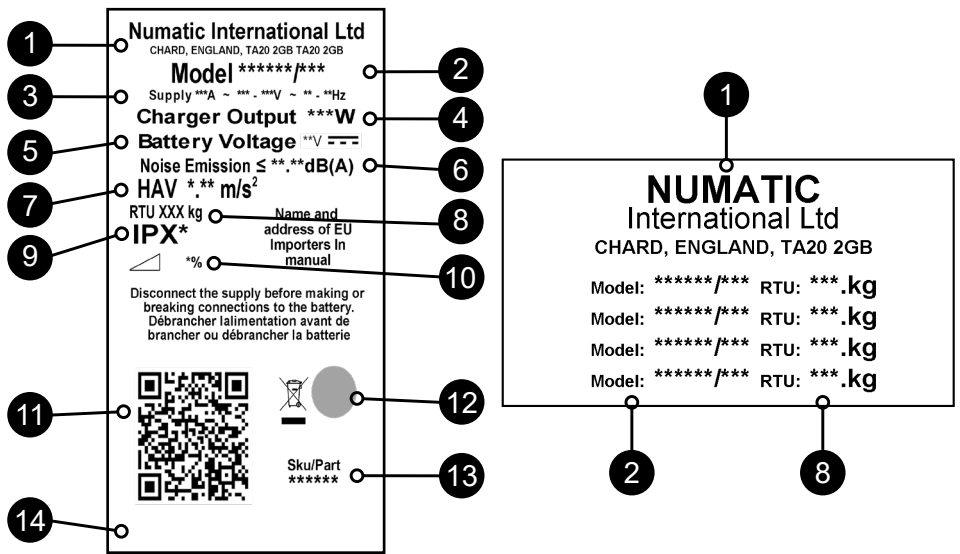

WEEE (Waste, Electrical and Electronic Equipment)

Scrubber dryer Accessories and packaging should be sorted for environmentally-friendly recycling. Only for UK & EU countries.

Do not dispose of scrubber-dryer into household waste.

According to the European Directive 2012/19/EU on waste electrical electronic equipment and its incorporation into national law.

Scrubber-dryers that are no longer suitable for use must be separated, collected and sent for recovery in an environmentally-friendly manner.



PPE (Personal protective equipment) that may be required for certain operations.

Ear Protection	Safety Footwear	Head Protection	Safety Gloves	
				Caution Wet Floor Sign
Dust / Allergens Protection	Eye Protection	Protective Clothing	Hi-Vis Jacket	

Note: A risk assessment should be conducted to determine which PPE should be worn.

CAUTION



**No HOT drinks
when operating
this machine.**

Safety Critical Component:

Charging Leads: H05VV-F 3 Core x 1.0 mm²
Battery Charger: 100V-240V (50-60Hz)
DC Output: 25.6VDC, 20A

Information for Scrubber Dryer

READ MANUAL BEFORE USE



COMPONENT	INTERVAL	INSPECT FOR
Mains Lead	DAILY	Scuffing, cracks, splits, conductors showing
Brushes	DAILY	Bristle damage, wear, drive collar wear
Squeegee Blade	BEFORE EACH USE	Wear, cracks, splits
Filters	BEFORE EACH USE	Clogging and debris retention
Tanks	AFTER EACH USE	Rinse dirty water tank after use



Operators shall be adequately instructed as to the correct use of the machine.

As with all electrical equipment care and attention must be exercised at all times during its use, in addition to ensuring that routine and preventative maintenance is carried out periodically in order to ensure its safe operation.

Failure to carry out maintenance as necessary, including the replacement of parts to the correct standard could render this equipment unsafe and the manufacturer can accept no responsibility or liability in this respect.

When ordering spare parts always quote the Model Number / Serial Number specified on the Rating Plate.

Do not use on cleaning surfaces having a gradient exceeding that marked on the machine. While on ramps or inclines, avoid sudden stops. Avoid sharp turns. Use low speed down ramps. Clean only while descending (driving down) the ramp.

This appliance is not intended for use by persons (including children) with reduced physical, sensory or mental capabilities, or lack of experience and knowledge. Children should be supervised to ensure that they do not play with the appliance.

When detergents or other liquids are used, read the manufacturer's instructions.

Only use brushes provided with the appliance or those specified in the instruction manual.

The use of other brushes may impair safety.

A full range of brushes and accessories are available for this product.

Only use brushes or pads which are suitable for the correct operation of the machine for the specific task being performed.

It is essential that this equipment is correctly assembled and operated in accordance with current safety regulations.

When using the equipment always ensure that all necessary precautions are taken to guarantee the safety of the operator and any other persons who may be affected.

Wear nonslip footwear when scrubbing. Use a respiratory mask in dusty environments.

The machine, while charging, must be positioned so that the mains plug is easily accessible.

When cleaning, servicing or maintaining the machine, replacing parts or converting to another function the power source shall be switched off. Mains operated machines shall be disconnected by removing the power plug, and battery operated machines shall be disconnected by using top ON/OFF button on the battery.

In order to prevent unauthorised use of the machine the power key must be removed after use.

Machines left unattended shall be secured against unintentional movement.

When detergents or other liquids are used, read the manufacturer's instructions.



This machine shall be stored indoors only
This machine is for indoor use only.

NOTES: This machine is intended for commercial use, for example in hotels, schools, hospitals, factories, shops, offices and rental businesses.



- Ensure only competent persons unpack/assemble the machine.
- Keep your machine clean.
- Keep your brushes in good condition.
- Replace any worn or damaged parts immediately.
- Regularly examine the power cord for damage, such as cracking or ageing. If damage is found, replace the cord before further use.
- Only replace the power cord with the correct Numatic approved replacement parts.
- Ensure that the work area is clear of obstructions and / or people.
- Ensure that the working area is well illuminated.
- Pre-sweep the area to be cleaned.



- Use steam cleaners or pressure washers to clean the machine or use in the rain.
- Attempt machine maintenance or cleaning unless the power plug has been removed from the supply outlet.
- Allow any inexperienced repairs. Call the experts.
- Strain cable or try to unplug by pulling on cable.
- Leave the brush pad on the machine when not in use.
- Allow the machine to be used by inexperienced or unauthorised operators or without appropriate training.
- Use the machine without the solution tanks properly positioned on the machine, as shown in the instructions.
- Expect the machine to provide trouble-free, reliable operation unless maintained correctly.
- Run the machine over power cable during operation.
- Lift or pull the machine by any of the operating triggers, use the main handle.
- Remove the handle from the machine except for service and repair.

Information for Scrubber Dryer



READ MANUAL BEFORE USE

Precautions when working with batteries

1. Always wear protective clothing e.g. face visor, gloves and overalls when working with batteries.
2. Whenever possible always use a properly designated and well-ventilated area for charging.
Do not smoke or bring naked flames into the charging area.
3. Remove any metallic items from hands, wrists and neck i.e. rings, chains etc. before working on a battery.
4. Never rest tools or metallic objects on top of the battery.
5. When charging is complete disconnect from the mains supply.
6. The batteries must be removed from the machine before it is scrapped.
7. The machine must be disconnected from the supply when removing the battery.
8. To remove the batteries:- Disconnect machine from the mains supply (if charging) and ensure batteries are switched off using the button that is placed on the battery top. Disconnect hoses from separator and tanks.
Remove separator and tanks. Unscrew battery strap fixings and remove.
Undo battery terminals and remove. Remove batteries.
9. The batteries are to be disposed of safely, as according to local government guidelines.
10. Only use genuine Numatic replacement batteries.
11. Do not allow the batteries to become fully discharged; it may not be possible to re-charge them.
Batteries should not be discharged below 22.5 volts with 10 amps flowing.
12. Do not allow one battery to be discharged separately to the other.
13. Do not mix batteries from different machines.
14. The batteries fitted to this product are Lithium-ion (Li-ion), Lithium Iron phosphate (LFP) type.
The fitting of any other type of battery may cause a safety hazard.
15. Switch off the battery using top ON/OFF button before cleaning or maintenance.

Battery Care

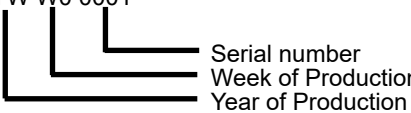
1. Battery Storage:
 - a. Batteries must be stored in a dry, level and clean location not exceeding a temperature range of 15°C ~ 25°C.
 - b. Batteries must be fully charged every 6 months when on-the-shelf or if the battery voltage reduces to 25V.
 - c. Batteries must be put into use within 12 months of the date of manufacture, failure to do so will lead to reduced capacity in the field. (battery date code) - ZP19006F YYW W0 0001

 - Serial number
 - Week of Production
 - Year of Production
 - d. If a battery does not want to switch ON and the green LED on the top is not illuminating, irreversible damage has occurred. Under this condition, a battery should not enter into service and should be disposed of according to local authority guidelines.
2. During Use:
 - a. Batteries must be recharged after every use regardless of machine run time.
 - b. If the machine is to be left dormant for any length of time complete the following:
 - i. Fully charge the batteries.
 - ii. Do not leave batteries dormant for more than 6 months.

Daily

Keep the machine clean.
Ensure brushes/ pads/ squeegee/ filters are in good condition.
Check for any worn or damaged parts and replace immediately.
Drain and rinse dirty water tank after every use.
Store machine with brush deck secured in the elevated position.

Weekly – as daily and –

Check brush or pad and skirt and rinse.
Check floor tool blades for wear and wipe clean.
Clean separator assembly including filter and check condition of seal.
Flush out system with clean water and clean filters.

Batteries

Always re-charge the batteries after use.
Charge for a minimum of 4 hours. Leave the battery on charge overnight, at least once per month.
After it has been fully charged, this will prolong battery life.

Twin Tec
Maintenance

Spare Parts

Part No.	BRUSHES
903449	370 mm Polyscrub Brush (2 required)
903994	370 mm Nyloscrub Brush (2 required)
606302	370 mm Long Life Brush (2 required)
900524	360 mm NuLoc2 Drive Board (2 required)

Numatic Recommended Battery	Part Number
NX1K LFP battery type (Li-ion)	911948

Make	Voltage	Capacity/Energy	Weight	Size
NX1K Battery	25.6 V	50Ah / 1280 Wh	10.7 kg	315mm (L) x 132mm (W) x 185mm (H)

For optimum performance Numatic International Ltd recommend the use of the following batteries in the Twintec machines.

Schematic Diagram

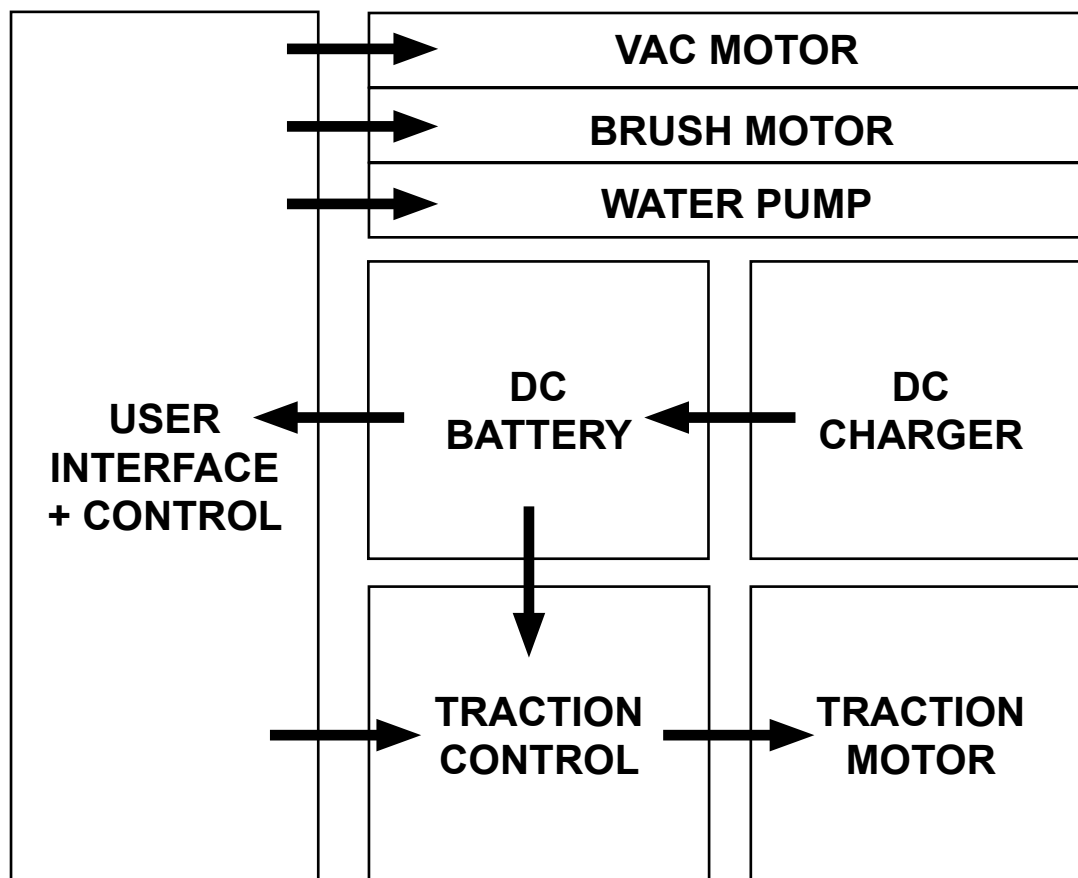

Wiring diagram is available on request. Please contact Numatic Technical help line +44 (0)1460 269268

Numatic Lithium-ion Rechargeable Battery

25.6V | 50Ah | 1280Wh | LFP26148129



It is important that you observe the following information and warnings!

Emergency Contact Information		
Address:	Shenzhen ACE Battery Co.,Ltd Room 201, BAK Technology Building, No. 9 Keyan Road, Maling Community, Yuehai Street, Nanshan District, Shenzhen, Guangdong Province 518054, P.R. China	NUMATIC INTERNATIONAL LTD Millfield Road, Chard, Somerset, TA20 2GB, UK
Tel:	0086-755-83283710	0044-146-068600
www.numatic.co.uk www.numatic.de www.numatic.ch www.numatic.fr www.numatic.nl www.numatic.co.za www.numatic.pt www.numatic.es		

1. DEFECTIVE BATTERIES

1. If a customer wishes to return a battery to a supplier after removing from product, then collection of the battery must be arranged by the supplier; however, **Faulty batteries must not be returned through the postal system or by courier.**
2. If on return to a supplier, OR at a customer base, a suspected defective battery shows any signs of impact damage, distortion, blistering, loose parts or leakage then on no account should it be offered for condition checking. It must be considered defective and the procedures described from item 6 below should be followed.
3. If, on return to a supplier, OR at a customer base, a suspected defective battery, that shows No signs of impact damage, distortion, blistering, loose parts or leakage, may be offered for condition checking with an appropriate battery condition checking device operated by a competent person.
4. If checking shows the battery to be defective then the procedures described from item 6 below should be followed.
5. **On no account must any further attempt to recharge be made. A defective battery should not be stored inside buildings on any account.**
6. The defective battery must be switched off, and all electrical terminals sufficiently insulated to remove risk of short circuit. The defective battery can then be stored in a locked battery waste container which should be plastic or plastic lined and placed away from buildings and combustible materials and clearly signed as a defective battery container with appropriate warnings. Defective batteries should be sent for waste disposal / recycling according to your country waste regulations.

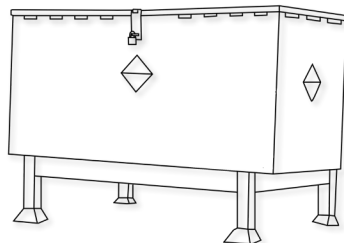

An example of a waste battery storage bin well away from buildings.

2. HANDLING AND STORAGE

DANGER!

Improper handling can lead to an explosion or ignite a fire!
Store batteries out of reach of children.

- Only trained staff can fix the battery in the machine.
- Storage temperature range: -10°C~40°C.
- Temperatures must not exceed 40°C.
- Relative humidity range: 20% to 80%.
- Optimum preservation of functionality: 15°C~25°C.

WARNING:

- Do not open the battery, disassemble it or allow it to fall from a substantial height.
- Protect the battery against short-circuiting – danger of explosion!
- Protect the battery against rain, do not immerse in liquids – danger of short-circuiting.
- Protect the battery against direct sunlight, heat and fire.
- Do not incinerate the battery – danger of explosion!
- Do not use defective or deformed batteries.
- Use only original Numatic specific appliances to charge and discharge batteries.

STORAGE:

- Good batteries should be stored in a protected area away from sources of direct heat and sunlight and should be kept dry.
- The temperature should not exceed 40°C but preferably not be above 25°C to maintain good battery performance.
- Storage area should be of low humidity, non dusty and a non corrosive atmosphere.

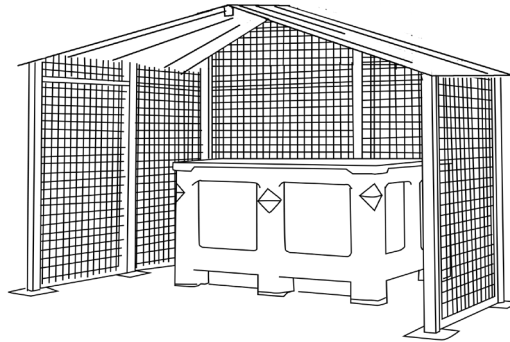

- An example of a well protected area with a cage to protect against accidental impact damage and with the batteries stored in a protective container to protect from heat, impact and accidental spillage of liquids.
- Care when handling / moving with forklift trucks or pallet trucks is needed at all times to avoid any physical damage to the batteries.
- If a good battery at any time is mishandled or subjected to any conditions that may damage it, as described in the battery Instruction manual supplied, it must then be considered as defective and procedures followed from Item 1 of this document overleaf.

3. HAZARDS IDENTIFICATION

- Electrolyte may escape from damaged batteries. Avoid contact.
- Contact can cause skin irritation, burns and chemical burns.
- If liquid comes into contact with eyes, seek medical attention.
- Avoid inhaling any vapours formed or released from the battery – Contains caustic alkaline electrolytes.
- Warning - Risk of fire - This battery contains No user serviceable parts.

4. FIRST AID MEASURES

In the event of contact with released electrolyte or electrolyte vapours:

- Eye contact – flush eyes for at least 15 minutes with plenty of clean water without rubbing and seek medical attention.
- Skin contact – wash affected areas of skin with plenty of water and soap; if irritation persists, seek medical attention.
- Inhalation – provide fresh air or administer oxygen immediately and seek medical attention.
- Ingestion – if electrolyte has been ingested, seek medical attention immediately.

Information for physicians:

- Contains caustic alkaline electrolytes in cells with Lithium Iron Phosphate – NO LITHIUM METAL OR LITHIUM ALLOYS.

5. FIRE FIGHTING MEASURES

- In case of fire – Keep clear of vapours and gases generated, take wind direction into consideration. If possible without danger, remove batteries from the vicinity of the fire. In principle, cooling or extinguishing with water is possible, but should only be done by trained personnel with sufficiently large quantities of water.
- If the hazard situation is unclear, extinguish only with ABC powder extinguishers (Class D extinguishers for fires involving metals are especially suitable).
- Fire fighters should only approach the fire wearing protective clothing and self-contained breathing apparatus.
- Once the fire has been extinguished, as a rule, the area should be monitored (fire watch) and cleaned up by trained and appropriately equipped personnel; fire residue should be contained and disposed of properly.

6. EXPOSURE CONTROLS, PERSONAL PROTECTION

Respiratory Protection:

- In case of battery venting, providing as much ventilation as possible. Avoid confined areas with venting batteries.
- Respiratory Protection is not necessary under conditions of normal use.

Ventilation:

- Not necessary under conditions of normal use.

Protective Gloves:

- Not necessary under conditions of normal use.

Other Protective Clothing or Equipment:

- Not necessary under conditions of normal use.
- Personal Protection is recommended for venting batteries: Respiratory Protection, Protective Gloves, Protective Clothing and safety glass with side shields.

7. ACCIDENTAL RELEASE

Disposal – Wear protective clothing and equipment, wipe up with absorbent textile and dispose of as hazardous waste at collection points for hazardous waste according to national regulations.

8. DO

- Use NUMATIC batteries only with NUMATIC appliances and charge them only using NUMATIC chargers.
- Charge battery before use.
- Store the battery out of the reach of children.
- Protect from rain – do not immerse in fluids.
- Protect from direct sunlight, heat, and open flames.
- Keep a battery that is not in use away from metal objects, (e.g. nails, coins, jewellery).
- Follow the disposal advice of the manufacturer and any internal waste management guidance.
- Use and store the battery with-in temperature range (as shown in Temperature Range Table).
- Always switch off the battery using the button by holding it for 6 seconds, before disconnection and handling.
- To activate / turn ON the battery please hold the top button for 6 seconds **or alternatively** charge the battery using original Numatic specific chargers.



Warning: The battery must only be charged by the Numatic Charger supplied with the product and under NO circumstances should an alternative non Numatic charger be used as there is a risk of severe damage and fire could result.

Note* "If batteries are subjected to temperatures beyond normal operating limits automatic shutdown will occur. Under these conditions allow the batteries to acclimatise at room temperature (18°C – 22°C) for several hours to allow the battery to wake up".

Temperature Range Table	
CHARGING	5°C~35°C
DISCHARGING	-10°C~35°C
STORAGE OPTIMUM	15°C~25°C
STORAGE LIMIT	-10°C~40°C

9. DO NOT

- Throw battery into fire – risk of explosion!
- Charge or use a defective, damaged or deformed battery.
- Open, damage or drop the battery.
- Expose the battery to microwaves or high pressure.
- Bridge (short circuit) the battery terminals with metallic objects since this may damage the battery.
- Use metal containers for transporting batteries.
- Expose the batteries to high temperatures including direct sunlight.
- Crush, break open or physically abuse the batteries or the equipment that contains them.

10. DISTRIBUTOR TAKE-BACK / DISPOSAL



- On the basis of the Battery Directive, the manufacturers take responsibility for financing collection, treatment and recycling of batteries used in devices. To this end, batteries must be handed over for disposal to the collection systems established for this under national law. Disposal of batteries together with household waste is prohibited; batteries must be collected separately according to type.
- Return the battery free of charge to your NUMATIC servicing dealer for disposal or hand it over to an appropriate public collection point.

11. CHARGING BATTERIES

- The charger is intended for use only in the machine where it has been installed. The charger is intended for use with the detachable power cord supplied, the power unit is capable of operating at different voltages without user adjustment. If the charger is damaged or does not charge anymore, please return to service centre.

CAUTION!

- Check the mains cord regularly for any sign of damage.
- Do not use damaged devices.
- If the mains cord of the charger is damaged, it must be replaced by an original NUMATIC mains cord available from the manufacturer or service agent.

12. WARRANTY

Lithium-Ion Battery Warranty

Warranty: Commercial Use

- a. Batteries are warranted for (3 Years) as standard, providing all battery care rules are followed. *Note Numatic dealerships outside of the UK may provide longer warranty periods. Please confirm with your local Numatic dealership on purchase of your product.
- b. To claim warranty the following details must be supplied
 - i. Serial number of the machine
 - ii. Battery date code
 - iii. Date purchased
 - iv. Proof of Purchase
 - v. Maintenance history and charging regime

Failure to use the correct Numatic charger will void your warranty.

Notes

Numatic International *Warranty*

Numatic International Limited warrant to the original purchaser that its products are free of defects in both material or workmanship for the period shown below:-

Homecare and Cleancare Vacuum cleaners.....	2 Years
Rotary Floor Machines.....	2 Years
Twintec Auto Scrubber Dryer.....	1 Year
Vario Ride-On Scrubber Dryer.....	1 Year / 1500 hours
Mopping, Compacts, Combi and Servocare Products.....	1 Year
Individual Accessories and Spare Parts.....	6 Months

Note: This warranty expressly excludes consumable parts such as carbon brushes, floor brushes, mops, batteries etc, that are considered replaceable from time to time during the normal working life of the machine.

- A. The warranty period commences from the date the goods are purchased.
- B. All warranty claims must be processed through the Dealer from whom the equipment was purchased. The Dealer will co-operate with the purchaser throughout the warranty claims procedure and will arrange any necessary repairs using genuine Numatic parts.
- C. If the original Dealer is no longer able to fulfil his obligations please contact Numatic International Limited with full details of the claim and proof of purchase so that this may be processed without delay.
- D. Any warranty claim can only relate to the specific part that is proven to be at fault and for which a replacement will be supplied but cannot be extended to constitute a claim against the complete machine.
- E. Numatic International will supply the Dealer with any warranty parts required, subject to the claim being validated, after return of the faulty items in accordance with Numatic International Limited's General Conditions of Sale.
- F. Claims will not be accepted if they are the result of fair wear and tear, misuse or abuse of any kind.
- G. No replacement will be given unless the appropriate evidence of the validity of the claim has been provided to the satisfaction of Numatic International Limited.
- H. Numatic International Limited reserve the right to charge for any unnecessary work carried out as a result of an invalid claim.
- I. No variation to this warranty may be made or implied by any member of Numatic International Limited or its Dealers unless such variation is in writing and authorised by the Company

Numatic International Limited. Chard, Somerset, TA20 2GB

Telephone: 01460 68600 Fax: 01460 68458

© Numatic International Limited

UKCA Declaration of Conformity	
Manufacturer:	Numatic International Limited Chard Somerset TA20 2GB www.numatic.co.uk TGB8572, TBL8572
Product:	Floor Treatment - Walk Behind – Commercial - Battery
Description:	
We, Numatic hereby declare under our sole responsibility, that the above-mentioned product(s) is/are in conformity with the following directives and standards.	
S.I. 2008: 1597	Supply of Machinery Regulations EN60335-1:2012 + AC:2014 + A11:2014 + A13:2017 + A15:2021 EN60335-2-72:2012 EN62233:2008
S.I. 2016: 1091	EMC Regulations EN55014-1:2017 + A11:2020 EN55014-2:1997 + A1:2001 + A2:2008 EN61000-3-2:2014 EN61000-3-3:2013
S.I. 2012: 3032	RoHS Regulations

EU, EC, EL, UE, ES: Declaration of Conformity Prohlášení o shodě Konformitátserklärung Overensstemmelseserklæring Declaración de conformidad Vastavusdeklaratsioon Déclaration de conformité	Декларация за съответствие Δήλωση συμμόρφωσης Megfelelősegi nyilatkozat Dichiarazione di conformità Izjava o skladnosti Vaatimustenmukaisuusvakuutus
Manufacturer: / Виробец / Hersteller / Fabricant / Fabricante / Toottaja / Fabricant / Производител / Катковпроизводитель / Gyártó / Fabbricante / Gaminiojas / Fabricant / Producent / Fabricante / Producent / Producător / Производители / Тилверкере / Proizvajalca / Valmistaja:	Numatic International Limited Chard Somerset TA20 2GB www.numatic.co.uk TGB8572, TBL8572
Product: / Προϊόν / Термék / Prodotto / Producto, Toodet, Produit / Изделие / Produkty / Termék / Товар / Produkt / Izdelka / Tuote:	Floor Treatment – Walk Behind – Commercial - Battery
Description: / Popis / Beschreibung / Beskrivelse / Descripción / Kirjeldus / La description / Описание / Περιγραφή / Leírás / Descriziune / Apibūdinimas / Omschrijving / Beskrivelse / Descrição / Opis / Descriere / Описание / Beskrivning / Opis / Kuvaus:	
EN We, Numatic hereby declare under our sole responsibility, that the above-mentioned product(s) is/are in conformity with the following directives and standards.	PT Nós, a Numatic declaramos, sob nossa exclusiva responsabilidade, que o produto acima mencionado está em conformidade com as diretivas e normas a seguir.
CS My, Numatic prohlašujeme na svou výlučnou odpovědnost, že výše uvedeny výrobek je ve shodě s následujícími směrniciemi a normami.	PL My, Numatic Niniejszym oświadczamy z pełną odpowiedzialnością, że wyżej wymieniony produkt jest zgodny z następującymi dyrektywami i normami.
DE Wir, Numatic erklären in alleiniger Verantwortung, dass das oben genannte Produkt den folgenden Richtlinien und Normen entspricht.	RO Noi, Numatic Prin prezenta declarăm pe propria răspundere, că produsul mai sus menționat este în conformitate cu următoarele standarde și directive.
DA Vi, Numatic erklærer hermed under eget ansvar at ovennævnte produkt(er) er i overensstemmelse med følgende direktiver og standarder.	RU Мы, Нуматик ови́м изъавляем под личном одговорношћу, да наведенор продукт је у складу са следећим директивама и стандардима.
ES Nosotros, Numatic declaramos bajo nuestra única responsabilidad que el producto antes mencionado está en conformidad con las siguientes directivas y normas	SV Vi Numatic förklarar härmed under eget ansvar att ovan nämnda produkt överensstämmer med följande direktiv och normer.
ET Meie, Numatic käesolevaga kinnitame ja kameame ainuühtlalt vastutust, et eespool nimetatud toode on kooskõlas järgmistega direktiivide ja	SL Mi, Numatic izjavljamo s polno odgovornostjo, da je zgoraj omenjeni izdelek v skladu z naslednjimi smernicami in standardi.
FR Numatic déclare sous notre seule responsabilité que le produit mentionné ci-dessus est conforme aux directives et normes suivantes.	FI Me, Numatic täten vakuumamme omalla vastuulla, että edellä mainittu tuote on yhdenmukainen seuraavien direktiivien ja standardien mukaisesti

2006/42/EC	Machinery Directive EN60335-1:2012 + AC:2014 + A11:2014 + A13:2017 + A15:2021 EN60335-2-72:2012 EN62233:2008
2014/30/EU	EMC Directive EN55014-1:2017 + A11:2020 EN55014-2:1997 + A1:2001 + A2:2008 EN61000-3-2:2014 EN61000-3-3:2013
2011/65/EU	RoHS Directive

Authorised Signatory: Mr. Matthew Coles

Position: Head of Technology
Numatic International Limited
Chard,

Signed: *M Coles*

Date: 1st February 2024

Somerset, TA20 2GB, UK

This Machine Has Been Packed
With The Following

Brush / Pad

Floor Tool

Charging Lead

Battery

Fuse Pack

Signed

Distributed by:

Numatic

numatic.com

Numatic International Limited (Head Office)

Chard, Somerset TA20 2GB, UNITED KINGDOM
Tel: 01460 68600 numatic.com

Numatic International GmbH

Fränkische Straße 15-19, 30455 Hannover, DEUTSCHLAND
Tel: +49 (0) 511 984 2160 numatic.de

Numatic International Denmark

Fränkische Straße 15-19, 30455 Hannover, DEUTSCHLAND
Tel: +45 (0) 316 40808 numatic-online.dk

Numatic International S.A.S

13/17 rue du Valengelier, EAE la Tuilerie, 77500 Chelles, FRANCE
Tel: +33 (0) 164 726 161 numatic.fr

Numatic International BV

Vennootsweg 15, 2404 CG, Alphen aan den Rijn, NEDERLAND
Tel: +31 (0) 172 467 999 numatic.nl

Numatic International Schweiz AG.

Sihlbruggstrasse 3A, 6340 Baar, SCHWEIZ
Tel: +41 (0) 41 768 0760 numatic.ch

Numatic International (PTY) Ltd.

Cnr. 16th & Pharmaceutical Road, Randjes Park, Midrand 1685, SOUTH AFRICA
Tel: +27 (0) 861 686 284 numatic.co.za

Numatic International ULDA

Rua Francisco da Silva Duarte, nº79,
4475-269 Santa Maria de Avioso, Castêlo da Maia, PORTUGAL
Tel: +351 220 047 700 numatic.pt

Numatic International Spain, S.L.U.

Av. Baix Llobregat, 5-7, Oficina bajos 1 (Parc Negocis Mas Blau II)
08820 El Prat de Llobregat (Barcelona), SPAIN
Tel: +34 93 647 22 22 numatic.es

Numatic International Italy S.R.L

Via Luigi Galvani, 2, Z.I. Talponedo, 33080 Porcia (PN), ITALY
Tel: +39 (0) 434 046 211 numatic.it

This Product has been comprehensively inspected and checked during every stage of its manufacture.
Including an in-depth electrical safety and functionality test.

Specification subject to change without prior notice
numatic.com © Numatic International Limited

914735 02/24 (A03)